

TRAVERSE SLIDER

Independent parking solution to maximise parking spaces



OVERVIEW

- Independent parking for cars in rows one after the next. The platforms are electrically driven and run on rails. One empty space in each row allows the cars to reach the row(s) located behind it.
- By laterally shifting the transverse sliding platform every bit of available space is utilized and maximised. The arrangement of the platforms provide the maximum use of driving lanes or space behind columns and in corners.
- Modular construction and depending on the site conditions it maybe possible to add to system capacity
- Maximum load per parking space is 2,000kg with option to increase up to 2,300 or 2,600kg

GENERAL DESCRIPTION

- The traverse sliding platform reduces traffic area and optimised all usable space
- Independent Parking Operation – up to 2 platforms with key-switch. From 3 platforms with programmable PC-touch screen
- Parking platform load capacity
 - Standard 2000kg – load per wheel 500kg
 - Optional 2600kg – load per wheel 650kg

APPLICATION

- Multi-residential developments
- Townhouse developments
- Mixed use developments
- Replacing old systems



KEY DIMENSIONS

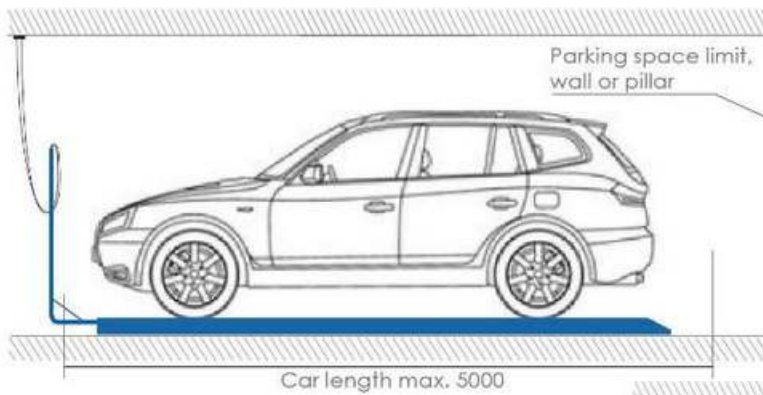
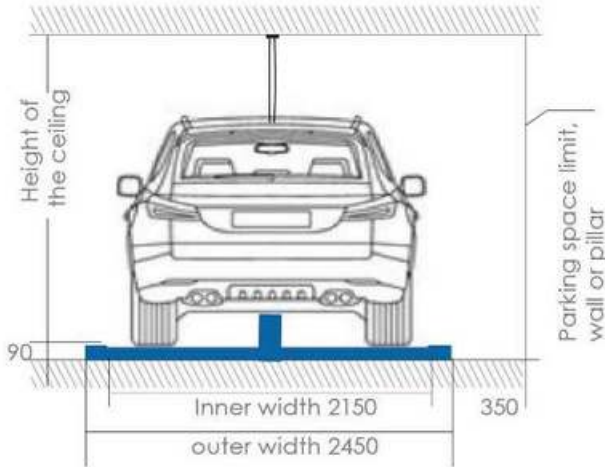

Inner Width	Outer Width
1,950	2,250
2,050	2,350
2,150	2,450
2,250	2,550

All measurements are in mm

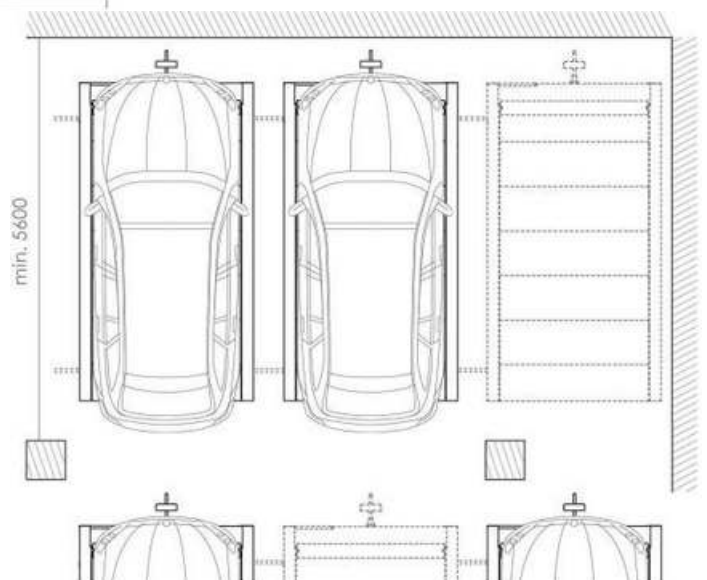

REQUIREMENTS

Control:

It must be possible to control the whole system the control unit, otherwise additional gates will be required.

Concrete Requirement:

Minimum 18, C25, floor evenness acc. to DIN 18202 tab. 3, line 3.

Car Height:

The car height must be at least 100mm lower than the ceiling height.

EXAMPLES OF USE

Images shown are only examples discuss your requirements and space for your project with Car Stackers Evolution

1 ROWED

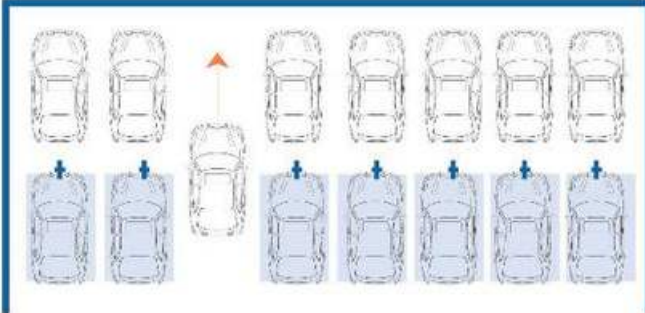

2 ROWED

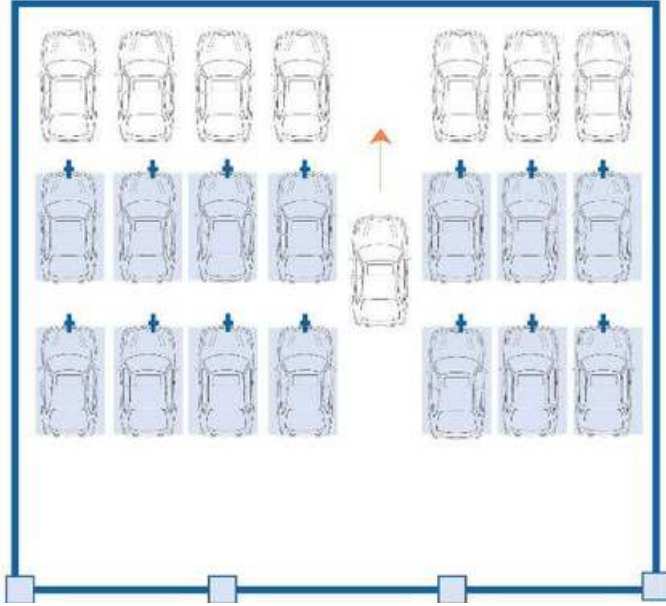

3 ROWED

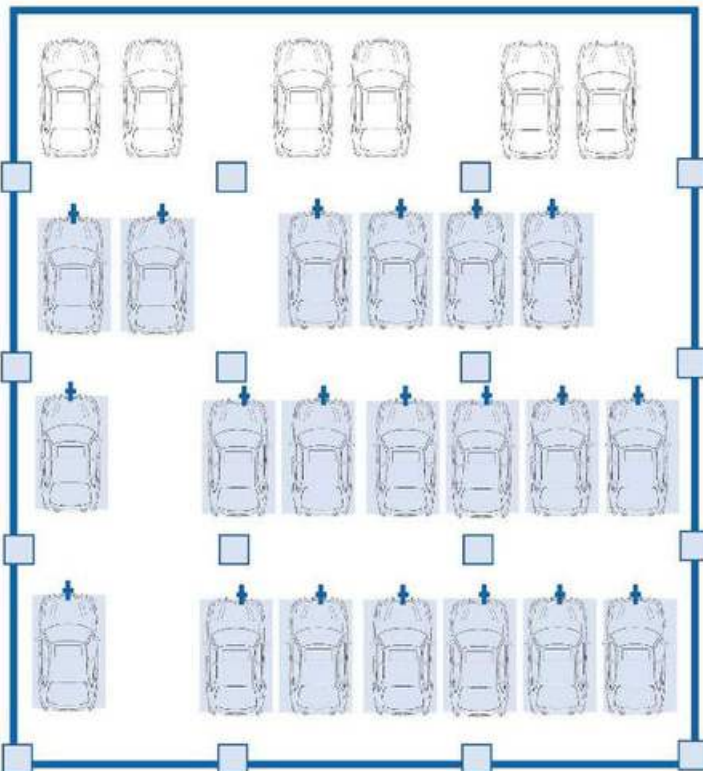

EXAMPLES EXPLAINED

Platforms next to and behind each other. It is possible to have several rows, the necessary empty space per row allows the platforms to slide. This way vehicles can drive in the space between the platforms until the last row and park.

It may be necessary to install intermediate stops within a single sliding movement, in order to move around pillars or any other obstacles there maybe in the space.

SAFETY DISTANCES & FLOORING

Distance from side wall and between platforms

Distance from back wall and between cars

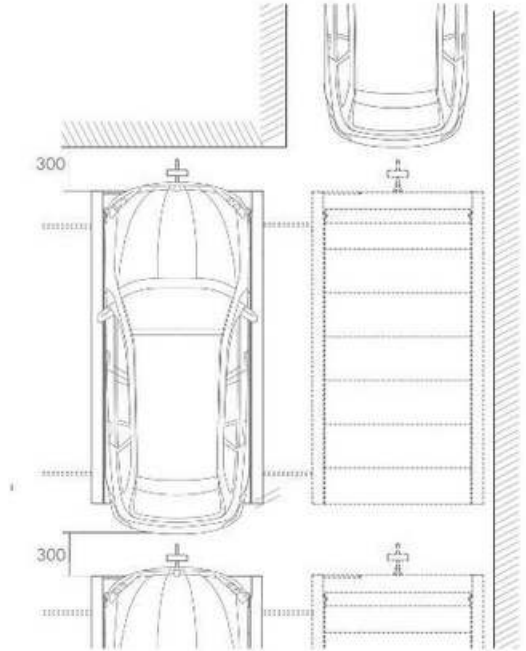
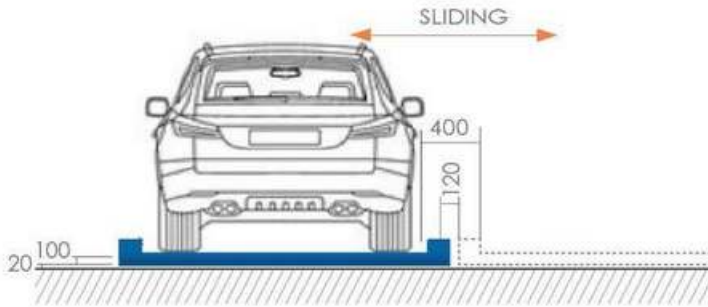

From DIN EN 14010:2009-12, 5.9:Safety of machinery – Equipment for power driven parking of motor vehicles.

If the safety standards can not be met due to building shape or other factors please discuss with Car Stackers Evolution to find a solution.

FLOOR TOLLARANCES

Acc. to DIN EN 14010, the max. safety distance between the lowest part of the parking platform and the floor shall not be more than 20mm. Therefore it is necessary to ensure that the floor features the necessary evenness (suggested material: screed). Please comply with the driving lane's floor evenness tolerances acc. to DIN 18202, tab. 3, line 3.

COLUMN	1	2	4	10	13	14
GROUP	APPLICABLE TO	Position deviations (limit values), in mm, for distances between measuring points, in m, up to				
2	unfinished upper surfaces or floors, subfloors and concrete bases subject to more stringent requirements (e.g. to receive floating screed, industrial floors, tile flooring and bonded screed), and finished surfaces for minor purposes (e.g. in storerooms or basements)	0.1 5	1 8	4 12	10 15	15 20
3	finished floors (e.g. screed as wearing courses or screed to receive a flooring, trowelled or bonded floorings)	2	4	10	12	15

All measurements are in mm

Load Forces

Foundation and pit walls must be planned so that they can absorb the loads of the parking system according to the schematic diagram shown on the right. If necessary, in case of heightened foundation requirements, the chemical anchors must be provided by the client. The borehole for the footplates of the parking system must be 180mm deep. Foundation, walls and ceilings are the responsibility of the customer and must be completed prior to Car Stackers Evolution beginning install. Area must be correct dimension, clean and dry. Concrete quality needs to be at least: C25/30.

Ground View

Side View

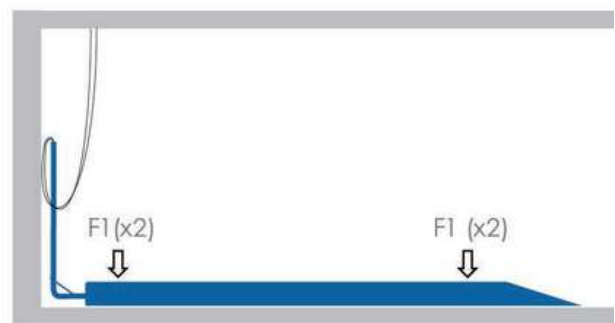
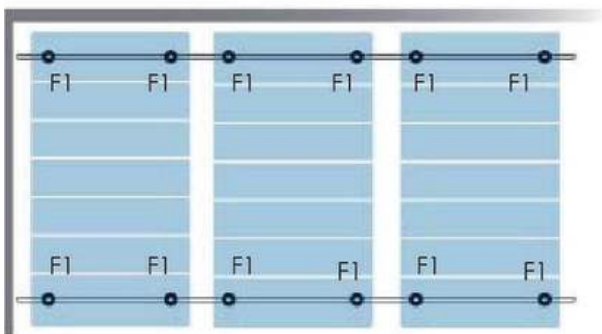

Driving lane

LOAD PER PARKING SPACE	LOAD (F1) ROLLS
2,000Kg	8.1kN
2,300Kg	9.1kN
2,600Kg	10kN

The information for the load F1 are to be multiplied for 4 rolls



We Know Car Stackers

OPTIONAL EXTRAS

- Aluminum premium floor coverings
- Catwalks on floor for added comfort on walkways
- Manual or electric gates
- Additional control units
- Additional flashing lights for increases safety
- Remote control for ease of use and access
- Corrosion protection

Regular service and maintenance is recommended on your machine. Service Division Australia offer periodical service and maintenance agreements.



IMPORTANT NOTES

Electrical installation

Prior assembly the customer must provide a lockable main control switch out of the system/pit close to the power unit. Electrical services to be provided by the customer to required specification.

Fire protection:

The customer must agree upon the fire protection requirements and the required measures with the local fire department.

EG-Machinery directive:

Our parking systems comply with the EG-Machinery directive and are CE certified according to DIN EN 14010:2003 and meet AS5124:2017

Safety of machinery - Equipment for power driven parking of motor vehicles - Safety and EMC requirements for design, manufacturing, erection and commissioning stages (EN 14010:2003, MOD)

Ramps' inclination:

Ramps leading to garages shall not have more than 15% inclination.



☎ 1800 069 784

✉ info@polite.com.au

🌐 carstackers.com.au