

EVOLUTION PARKING SYSTEM

EvolutionParkingSystem-turnsoneparkingspotintotwo,withthesimpleturnofakey.



OVERVIEW

- Simple and easy to use. The top vehicle is driven onto the rotating platform, without the need for awkward maneuvering. The state of the art technology gives independent access to both the
- top and bottom vehicles, allowing the top car to be retrieved without having to move other vehicles around. The top car is simply lowered and ready to go. This also allows 2 different vehicle owners to use this one stacker, Installation of the Evolution Parking System does not require any
- civil works, given there is suitable clearance the unit can be retrofitted in an existing area.

ABOUT

GENERAL DESCRIPTION

- Independent parking turning one spot into two
- Easy installation – could be retro fitted into existing developments
- Standard load capacity 2000kg per parking space, optional max to 2600kg.

APPLICATION

- Multi-residential developments
- Townhouse developments
- Mixed use developments
- Existing developments

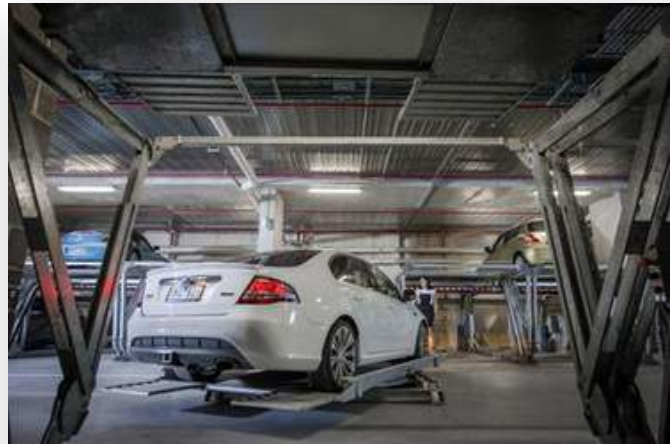

KEY DIMENSIONS



MACHINE TO DIMENSIONS

Dimensions	Closed Position	Open Position
Length	4,900	10,550
Width	2,640 or 2,540	5,330
Height	2,100	2,100
Unit Weight	1650kg	

LOAD CAPACITY

Max Values	Bottom Car	Top Car
Length	4,900	4,900
Width	2,000	2,000
Height*	1,500	**
Distance between Axels	4,900	2,800
Car Weight	UNLIMITED	2000KG
Front Axel Load	UNLIMITED	1200KG
Rear Axel Load	UNLIMITED	800KG

REQUIREMENT

Maximum vehicle height on upper Level:

1500mm . With a ground to ceiling clearance of 3400mm

Maximum vehicle height on Lower Level:

1550mm

Power Requirement:

415V, 50 Hz, 8amp

* Height including all elements attached to roof like antennas

** Top car maximum height is ceiling height minus 1,900mm

*** for top car 1,500mm minimum ceiling height required is 3,400mm

All measurements are in mm

KEY DIMENSIONS

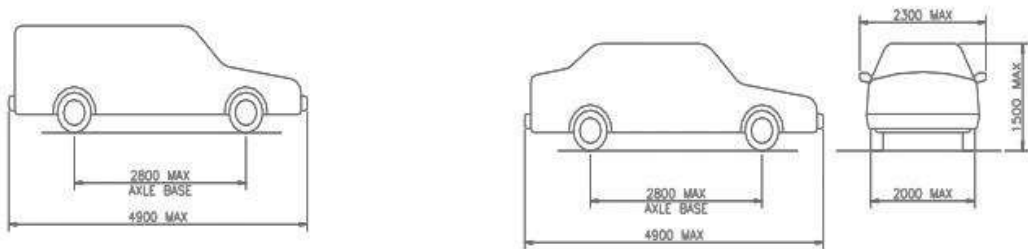

LOADS	
Normal Max Load	2000kg
Machine Self-Weight	1650kg
ELECTRIC SUPPLIES	
Power	2.2KW
Current	3*6A (for each machine)
TEMPERATURES	
Extreme Temperature	-30 to + 60 degrees celsius
GROUND SLOPES PERMISSIBLE FOR INSTALLATION	
Max. Lateral Slope	1%
Max. Longitudinal Slope	3%
LIGHTING REQUIREMENTS	
An ambient lighting of 20 LUX minimum converted lighting can be supplied by customer for each machine	

MACHINE STRUCTURE

GENERAL – THE MACHINE IS BUILT OF MAIN UNITS

1. Permanent base

Built of 6mm thick steel ST37 welded with CO2 welding
The base can carry any vehicle up to 2260kg w/o permanent deformation
The base is connected to the floor with 4 anchor bolts Ø12X120
The front two anchor bolts are loaded for pulling of 500kg each

2. Mobile base

Built of 6 joints made of 5mm thick steel ST37 welded with CO2 welding
The joints provide maximum stability of vehicle both in front and rear entrance of vehicle and throughout the motion of the mobile base

3. Rotating platform

Built of hot galvanized steel
Sealed for preventing leaks of water and oil from up mounted car to the bottom car
Platform edges are equipped with 2 rising slopes to enable vehicle entering and exiting
The platform is located on a steel rotating steel frame

4. Motor / gear for mobile bases

Three phase motor gear 2.2KW with IP55 protection for indoor and outdoor use, with an integral brake that closes when there is a power failure (of any kind)
The motor operates two circular chains 1.25" each with a sprocket wheel
The chain is linked to the arm of the mobile base
Upward motion of the machine pulls the arm along the guiding track on the permanent base from back to front
Downward motion of the machine pulls the arm along the guiding track on the permanent base from front to back.

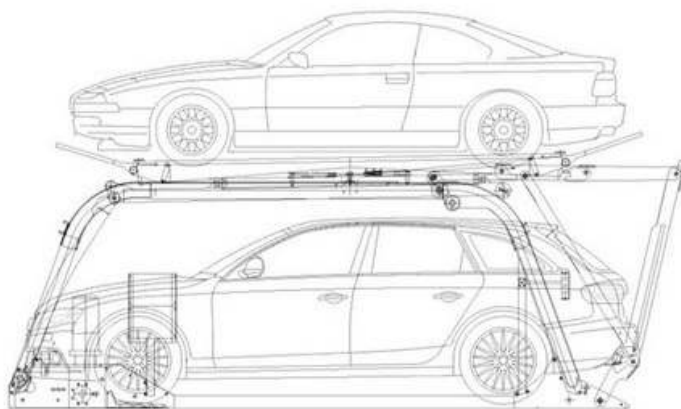

MACHINE STRUCTURE

5. Motor gear for rotating platform

Three phase motor gear 0.25KW with IP55 protection for indoor and outdoor use.

Motor is located on the mobile base

The motor pulls a driving belt that moves by friction the rotating frame

The rotating frame lifts and lowers the movable slopes by the use of cam, two arms and a steel cable.

6. Electrical Cabinet

The electricity cabinet is IP55 protection for indoor use and outdoor use.

The electricity cabinet provides three phase current to the permanent base motor and to the mobile

base motor, it provides 24V DC to the operating panel

The cabinet is protected by a main switch

7. Operating position

Operating position is located on the left hand side of the machine

Operating position includes a control panel with individual key switch, hold to run push button and an EMERGENCY-STOP red button

8. Acoustic warning signal

The machine is equipped with an audible warning sign that has an up and down warning beeper that is heard all along machines operation.

INSTALLATION

MINIMALSPACE FOR INSTALLATION

The machine can be installed either in open (wind protected) area or in closed area

- In both cases of installation there has to be a free space around the machine to ensure safe entry and exit of the vehicles
- Recommended minimal space on both sides of close machine is 700mm when installed in a single garage. Otherwise systems can be installed directly next to one another when Two or more systems are installed in a row.
- Mandatory space between machine front and wall is 200mm minimum

Parameter	Lateral Entrance	Parallel Entrance
Length	10.55m	10.55m
Width Ceiling	2.64 / 5.33m	5.33 / 2.64m
Height	3.40 m	3.40m

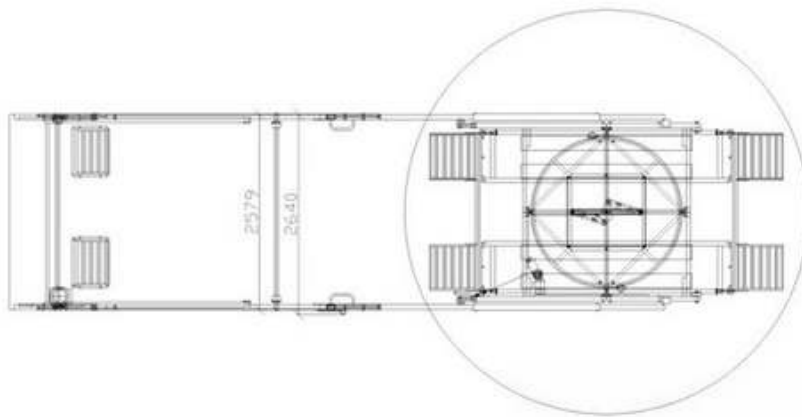

SERVICE & MAINTENANCE

Regular service and maintenance is recommended on your machine. Service Division Australia offer periodical service and maintenance agreements.



ANCHORING

ANCHORING TO THE GROUND

The machine is to be installed and anchored to a rough floor surface such as concrete or gravel

- The following conditions must be followed:
 - Maximum lateral floor slope should not be exceed 1%
 - Maximum longitudinal slope along open machine should not exceed 3%
 - Lateral floor curvature will not exceed 2.5cm
 - Longitudinal floor curvature will not exceed 2.5cm
- The machine will be anchored in 4 points according to floor type
 - Concrete floor 15cm thick
 - Anchoring will be with cross section head anchor bolts /"X120
As shown in fig 1
 - Gravel floor with concrete fixing points:
 - Anchoring will be with anchors as shown in fig 2

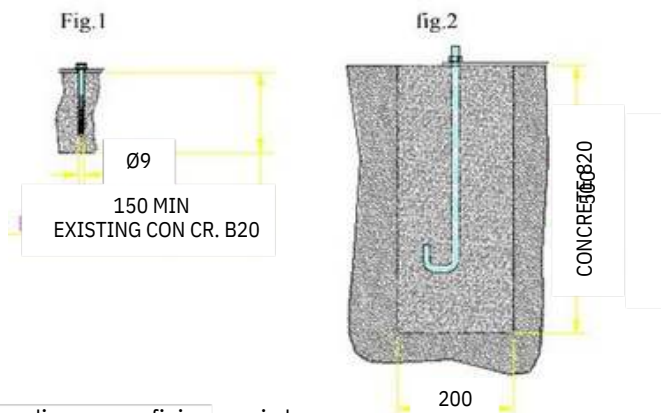

- Loadings per fixing point
 - Compression loading – 913kg.
 - Tension loading – Maximum of 1500kg
 - Maximum loading on 150mm thick concrete slab is 1000kg

ELECTRICITY SUPPLY

- Three phase power 5 X 3.5mm
- Automatic circuit breaker 3 X 16A
- Power point will be located no more than 2 m from machine

LIGHTING SUPPLY

- The customer will supply lighting as following:
 - 20 lux-converted lighting for each machine