

## DUPLÉ

Dependent Two Level Above Ground Parking System



### OVERVIEW

- The Duplé is a dependent parking system on 2 levels
- The hydraulic Duplé is used to double the amount of car spaces
- Suitable for indoor and outdoor installation
- Easy access to vehicle doors
- Operation via key-switch
- Standard capacity 2000kg that can be upgraded to 2300kg or 2600kg per parking position.
- Platform widths of 2100mm – 2600mm
- Modular construction and depending on site conditions parking system maybe able to be extended

## GENERAL DESCRIPTION

- Dependent parking system on 2 levels
- The lower vehicles must be removed when lifting platform is lowered.
- 100% more parking spaces
- Operation via key switch with dead man safety switch

## APPLICATION

- Multi-residential developments
- Single-residential dwellings
- Mixed use developments
- Internal or external use

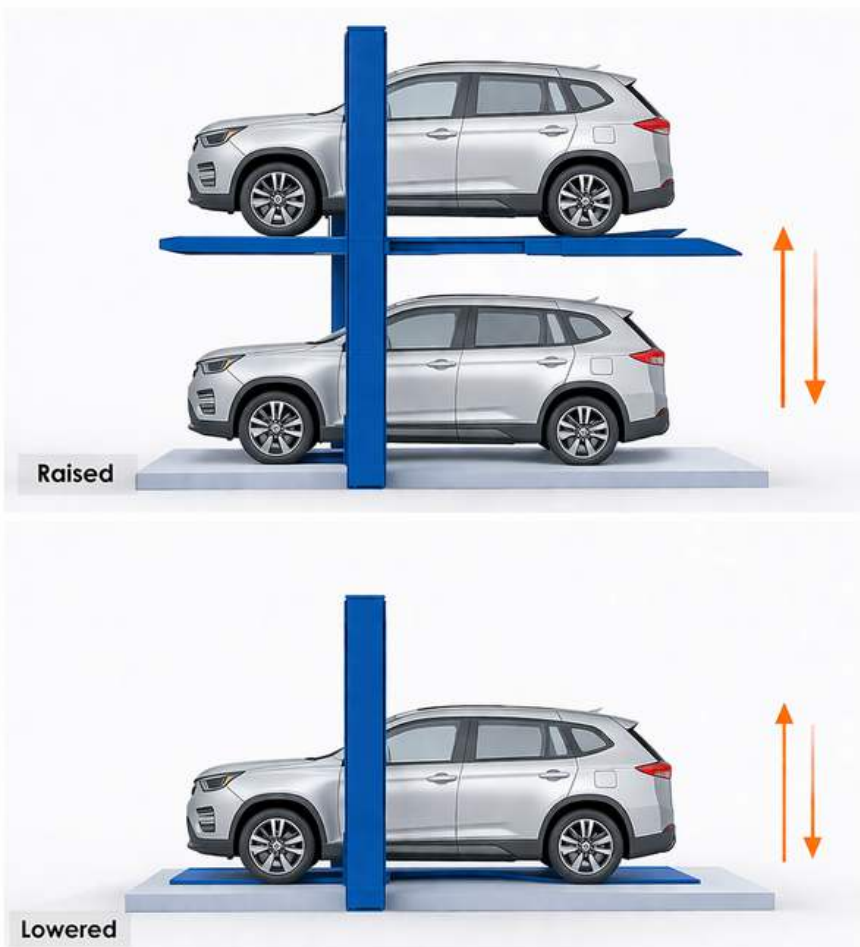

## KEY DIMENSIONS

CLEAR HEIGHT	COLUMN HEIGHT	CAR HEIGHT BELOW	CAR HEIGHT ABOVE
3,250 *	3,000	1,500	1,500
3,350	3,000	1,600	1,500
3,450	3,000	1,700	1,500
3,550	3,300	1,800	1,500
3,650	3,300	1,900	1,500
3,750 **	3,300	2,000	1,500

\*Example 1 – 3250mm Clear Height and 1600mm platform height  
Approx. car heights 1500mm (above car) 1650mm (below car)

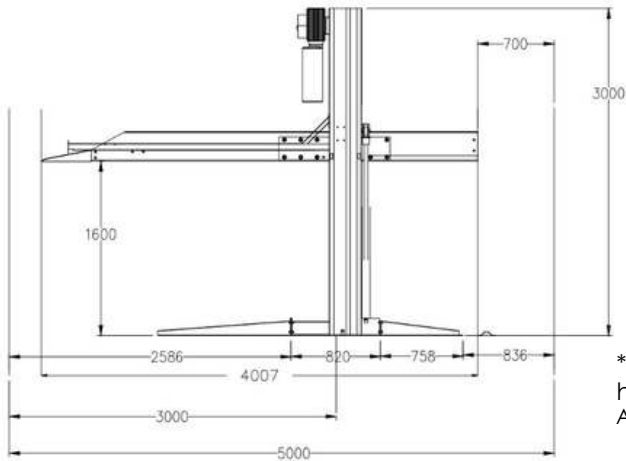

## REQUIREMENTS

Standard system length: To suit vehicles up to 5,000mm. With a maximum weight of 2600kg Platforms for vehicles outside of this scope would need to be discussed with Car Stackers Evolution.

### Vehicle Height:

The total height of the vehicle including roof racks and aerial must be considered in car height.

### Concrete Requirement:

Foundation and wall structure below the drive-level must be made of concrete, concrete quality at least: C25/30.

\*\* Example 2 – 3750mm Clear Height and 2100mm platform height  
Approx. car heights 1500mm (above car) 2050mm (below car)

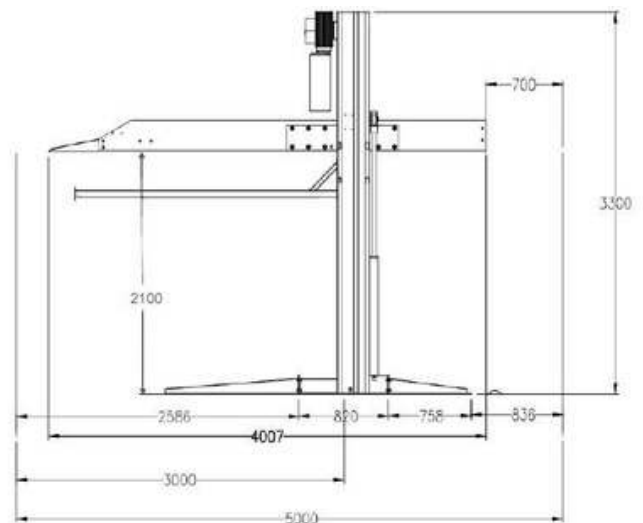

All measurements are in mm

### Additional items to note:

Power requirements: Builder to provide a 3-phase x 16amp Lockable Isolator  
Supply Line: (3PH + N + PE) with marked wire and protective earth conductor  
AMP: 16amp  
Voltage: 415V

Pump Noise: <60db

## LOAD FORCES

- Ensure the below load forces are taken into account in the construction design. Load forces are distributed to lower concrete slab via the base plates minimum area of 1500mm<sup>2</sup>.
- Base plate fastening using heavy duty masonry anchors with a depth no less than 150mm.
- Foundation and wall structure below the drive-level must be made of concrete, concrete quality at least: C25/30

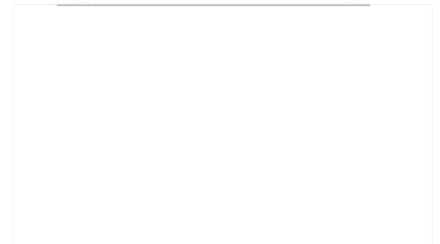
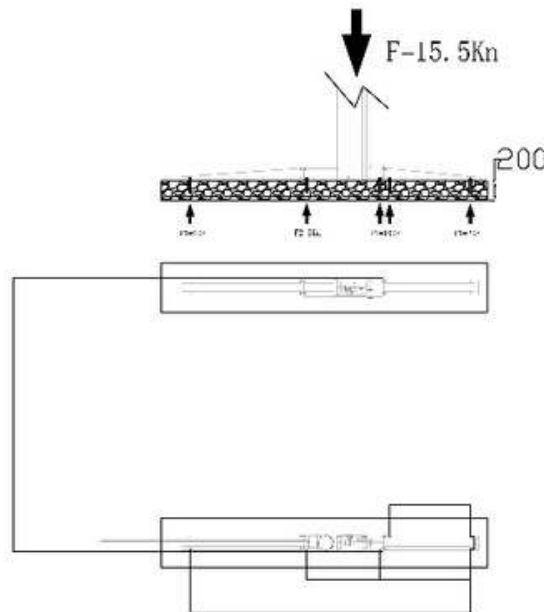
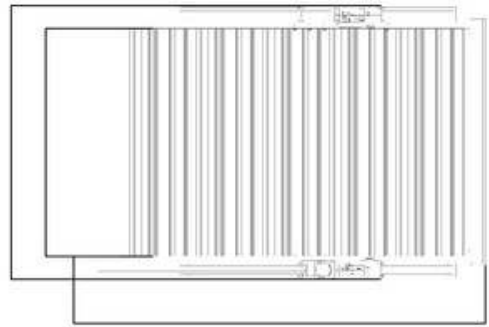
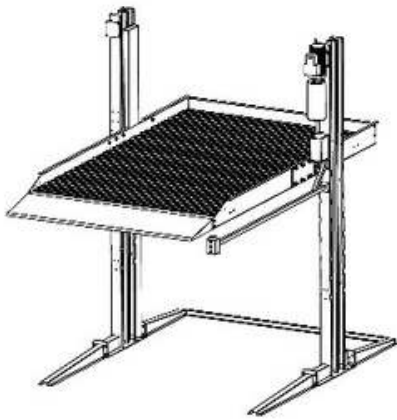

## LOAD FORCES

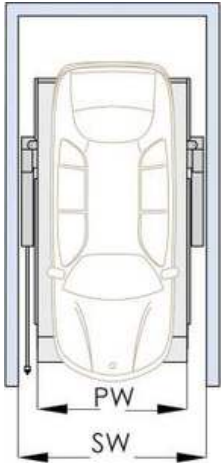

Space Needed SW	Platform Width PW
2567	2100
2667	2200
2767	2300
3867	2400
2967	2500
3067	2600
3167	2700

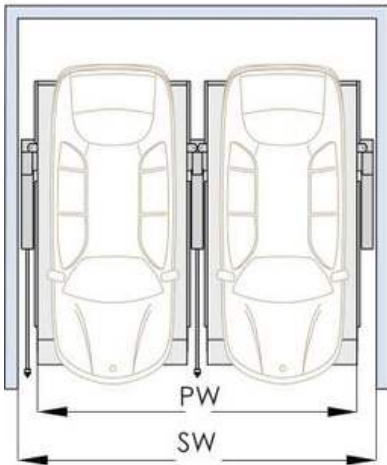

Space Needed SW	Platform Width PW
4949	2100
5149	2200
5349	2300
5549	2400
5749	2500
5949	2600
6149	2700

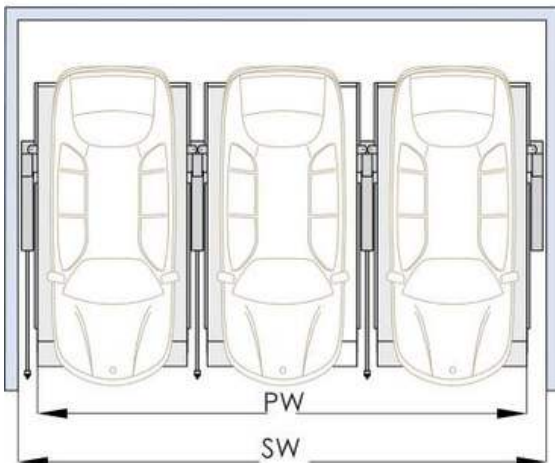

Space Needed SW	Platform Width PW
7331	2100
7631	2200
7931	2300
8231	2400
8531	2500
8831	2600
9131	2700

## **INSTALLATION**     **MOUNTING AND FIXING REQUIREMENTS**

- The stacker posts are fixed to the floor by using either wedge anchor bolts or chemically set studs to a depth of approximately 120mm.
- Concrete grade/strength class C20/25 is required, with a minimum thickness of 180mm
- Stackers can not be fixed to pavers or asphalt without concrete footings (as per the above grade/strength) being installed directly under the pavers or asphalt.
- The area where the stackers are to be installed must be even and flat to prevent the need for excessive shimming under the stacker posts. Shimming greater than 10mm will incur additional costs.

### **INSTALLATION NOTES**

- If the stacker(s) are to be installed in an outdoor location, then weather protection must be used for the power-pack/motor assemblies and the user control switches. This should be discussed with Car Stackers Evolution consultant, prior to ordering.
- Concrete grade/strength class C20/25 is required, with a minimum thickness of 180mm
- Stackers can not be fixed to pavers or asphalt without concrete footings (as per the above grade/strength) being installed directly under the pavers or asphalt.
- As stated previously; the area where the stackers are to be installed must be even and flat to prevent the need for excessive shimming under the stacker posts. Shimming greater than 10mm will incur additional costs.
- Expansion joints, etc., In the concrete floor must be a minimum of 300mm from our post fixings.

### **SAFETY**

- Automatic mechanical locking system is fully activated at all times when the platform is being raised.
- 24 Volt DC mechanical lock release solenoid is automatically engaged during the lowering of the platform.
- Photocell sensor accessory available to prevent accidental lowering of the platform.
- User friendly "smooth" finish platform surface is standard.
- Concealed synchronisation chain, keeping the platform stable and level at all times.
- Superior engineering means that no fixing to the building walls or ceiling is required, thus eliminating the potential for noise or vibrations transferring through the building.
- In accordance with ISO 3864 the client or builder must provide 100mm wide yellow black markings on the floor at a distance of 500mm from the front edge of the stacker platform.

## INSTALLATION

### CERTIFICATIONS AND STANDARDS

- TUV 2006/42/EC compliant. TUV is the most authoritative certification available in the world.
- EN 14010 compliant. Making the equipment compliant and available for sale in Europe.
- Meets and exceeds the Australian Standards 5124:2017
- Car Stackers Evolution equipment is TUV certified. TUV certification is the most prestigious certification that can be achieved by car stacking equipment

### TEMPERATURE

- The equipment is design to operate safely and effectively in a temperature range of -5 to +40 Degrees Celsius. If these ranges are likely to be exceeded, please discuss with Car Stackers Evolution

### ELECTRICAL

- A separately isolated 20-amp, 3 phase 440 volt (N +E) power supply is required for each car stacker.
- The provision of the power supply(s) to the agreed to location(s) is by the client or builder. All subsequent electrical work is carried out by the installer.
- Should any electrical conduits be required to be concealed or "cut-in", this is to be provided for by the client or builder. Please discuss with Car Stackers Evolution prior to the construction of any walls, etc. The Power Pack motor is rated at 2.2kW In accordance with the Australian Electrical Standards, each car stacker must be connected to the building earthed equipotential bonding.

### BARRIERS OR RAILINGS

- If there are walkways or passages directly adjacent to the sides or rear of the stackers, then a barrier, preventing access to the stacker area, must be provided by the client or builder and this barrier must comply to the relevant Standard in height and construction type.

### SURFACE PROTECTION

- All surfaces are either fully galvanized or powder-coated.
- All fixings are fully galvanized to the EN 14010 standard.

## INSTALLATION

### OPERATION

- Key Switch activated.
- Two keys per parking space are provided.
- Emergency Stop Button.
- Forward or reverse parking is allowed.
- Lifting speed is less than 50 seconds.
- Lowering speed is less than 45 seconds.

### DIMENSIONS

All dimensions in this Product Data Sheet as shown as the minimum and are to be read as being in millimeters, where not expressly shown.

Platform Widths	Row of 4	Row of 5	Row of 6	Row of 7	Row of 8	Row of 9	Row of 10
2100	6691	12073	14454	16836	19217	21599	23980
2200	10091	12573	15054	17536	20017	22499	24980
2300	10491	13073	15654	18236	20817	23399	25980
2400	10891	13573	16254	18936	21617	24299	26980
2500	11291	14073	16854	19636	22417	25199	27980
2600	11691	14573	17454	20336	23217	26099	28980
2700	12091	15073	18054	21036	24017	26999	29980

## MAINTENANCE

### SERVICE & MAINTENANCE

Regular service and maintenance is recommended on your machine. Service Division Australia offer periodical service and maintenance agreements.



## IMPORTANT NOTES

**Fire protection:**

*The customer must agree upon the fire protection requirements and the required measures with the local fire department.*

**EG-Machinery directive:**

*Our parking systems comply with the EG-Machinery directive and are CE certified according to DIN EN 14010:2003 and meet AS5124:2017*

*Safety of machinery - Equipment for power driven parking of motor vehicles - Safety and EMC requirements for design, manufacturing, erection and commissioning stages (EN 14010:2003, MOD)*