

# Car Lift

## ScissorWR

### Specification

- Stroke = up to 3700 mm
- Platform length = up to 6450 mm
- Platform width = up to 3000 mm
- Lifting capacity = up to 5000 kg <sup>1</sup>
- Estimated speed = 6 to 8 cm/sec



### Model with driver on board

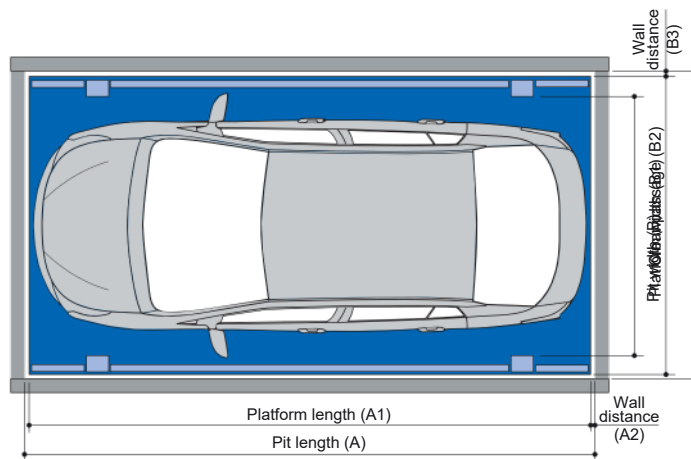
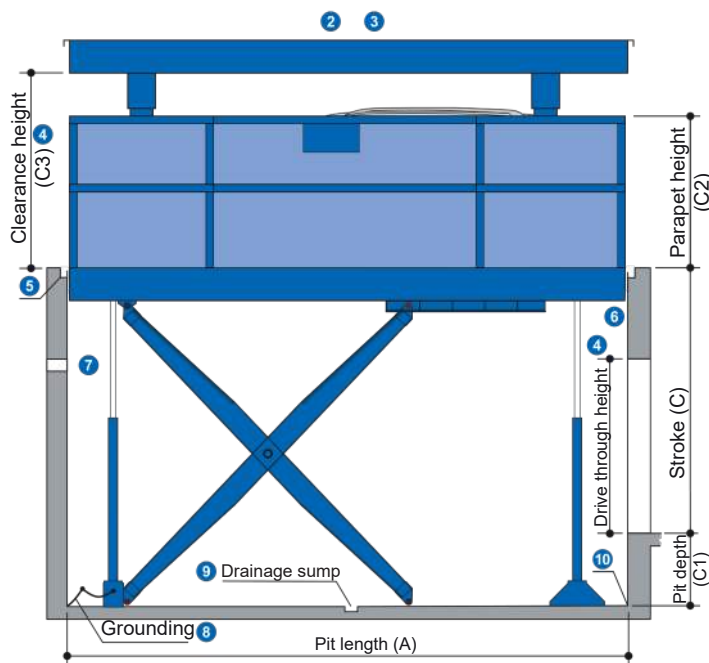

Parameter		Standard (mm)	Max (mm)
Pit length	A	5360	6500
Platform length	A1	5310	6450
Wall distance	A2	25	
Pit width	B	2500	3000
Platform width	B1	2450	2950
Clear passage	B2	2200	2700
Wall distance	B3	25	

Parameter		Standard (mm)	Max (mm)	
Stroke	Pit	C	2700	3700
depth	Parapet	C1	570 to 620	
height	Clear	C2	1200	2100
passage		C3	1800	2200

### Notes

- <sup>1</sup> Lifting capacity of the lift = Car to be lifted + Flooring weight on the roof of the lift (max. 250 kg/m<sup>2</sup>).  
For example: if the max lifting capacity of the lift = 5000 kg, Car to be lifted (3000 kg) + flooring weight on roof of the lift (2000 kg) should not exceed 5000 kg.
- <sup>2</sup> For countries with snowfall, the excessive snow on the lift is to be cleared before operating.
- <sup>3</sup> During the lowered position of the lift, the roof of the lift can be considered as a parking space under specific conditions. The vehicle parked on the roof should be removed before operating the lift.
- <sup>4</sup> Must be at least as high as the greatest car height + 5 cm.
- <sup>5</sup> Surrounding drainage system with connection to sewerage system to be performed by the customer (see "Drainage plan", page 4).
- <sup>6</sup> To comply with the minimum finished dimensions of the lift shaft, tolerances for space requirements <sup>+3</sup>/<sub>0</sub> according to VOB, Part C (DIN 18330 and 18331) and DIN 18202 must also be considered. Dimensions are in cm.
- <sup>7</sup> Ventilation inside the lift shaft has to be provided by the customer and must conform to AS 5124.
- <sup>8</sup> Grounding of the system to be connected to the central grounding on-site (to be provided by the customer).
- <sup>9</sup> Drainage sump : 10 x 2 cm with 50 x 50 x 50 cm drainage pit, install a sump pump (refer to manufacturer's dimensions).
- <sup>10</sup> At the transition section between the pit floor and walls, no hollow mouldings/coves are possible. If hollow mouldings/coves are required, the systems must be designed smaller or the pits accordingly wider.

Page 1  
Specification, Variants and Dimensions

Page 2  
Lift position, Lift with garage door, Approach

Page 3  
Drainage plan, Detail building construction

Page 4  
Loadplan, Electrical installation

Page 5  
Technical hints

Page 6  
Facilities from customer

Page 7  
Description

► Lift position

System raised

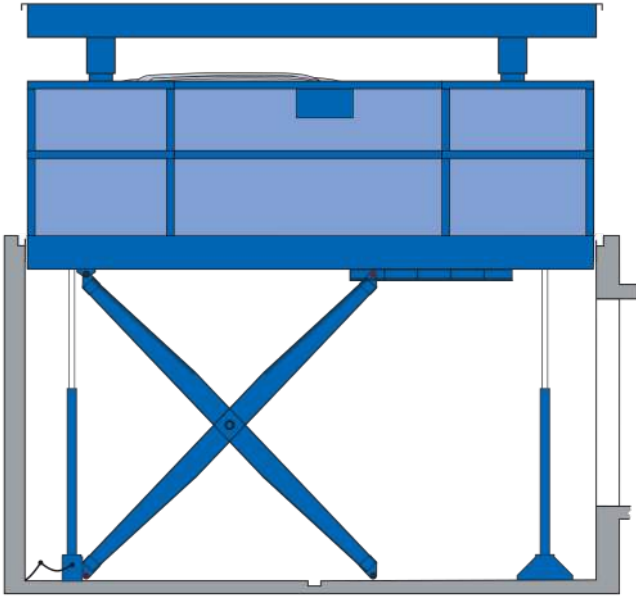

System lowered

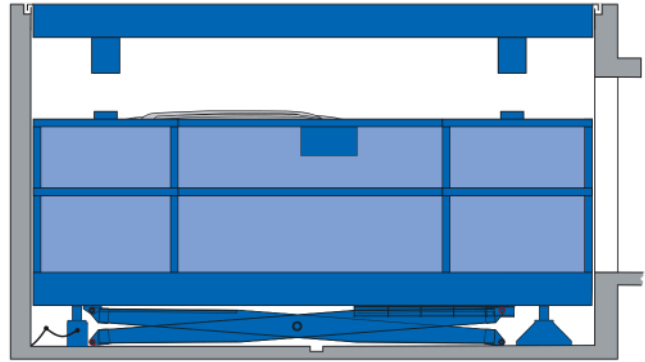

Page 1  
Specification,  
Variants and  
Dimensions

Page 2  
Lift position,  
Lift with  
garage door,  
Approach

Page 3  
Drainage  
plan, Detail  
building  
construction

Page 4  
Loadplan,  
Electrical  
installation

Page 5  
Technical  
hints

► Lift with garage door

Sectional garage door

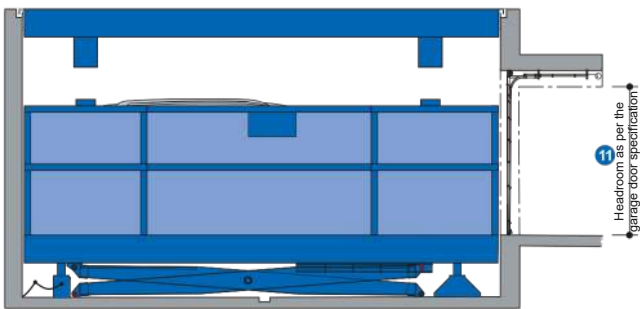

Roll-up garage door

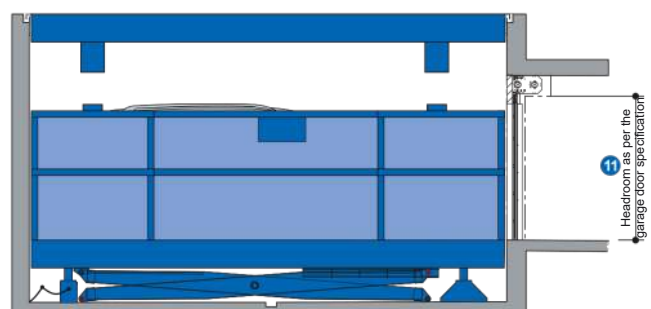

11 Dimensions for all doors must be coordinated with the door supplier. Coordination between the door manufacturer and **Car Stackers Evolution** is necessary.

Page 6  
Facilities from  
customer

Page 7  
Description

► Approach

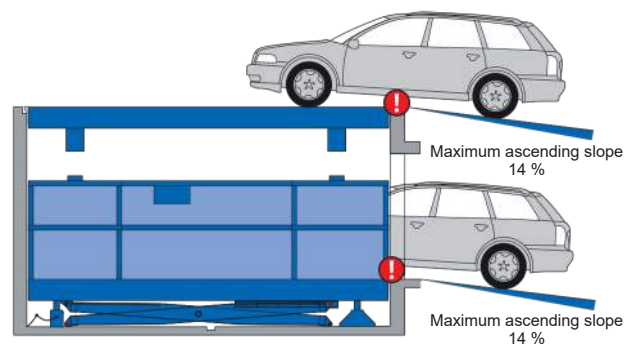
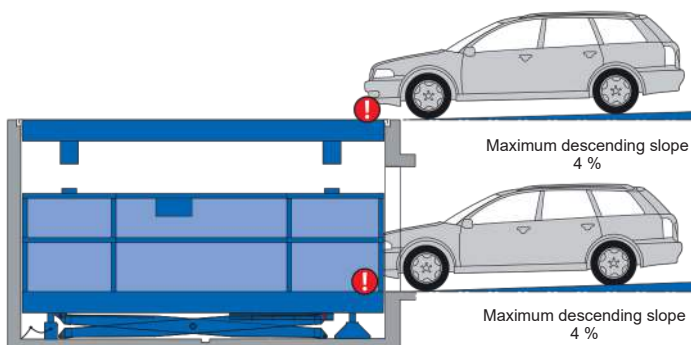

The illustrated maximum approach angles must not be exceeded. Incorrect approach angles will cause serious maneuvering and positioning problems on the parking system for which the company **Car Stackers Evolution** accepts no responsibility.

► Drainage plan

Overview of the pit

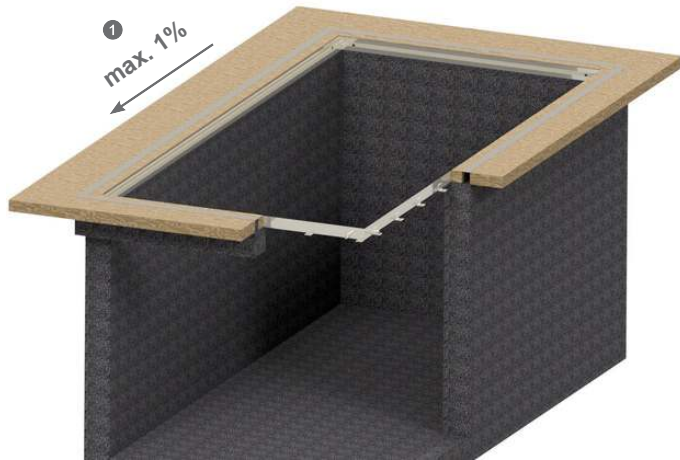

Section view of drainage channel

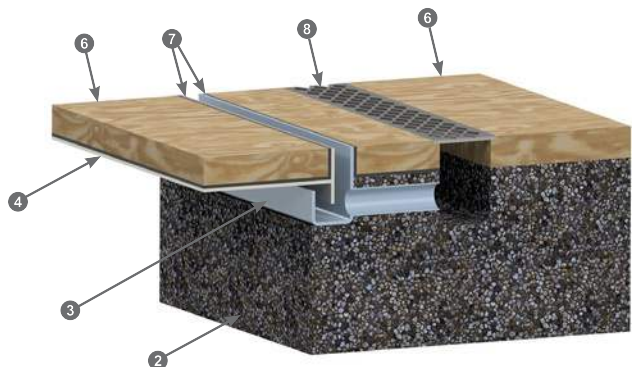

Section view of drainage channel

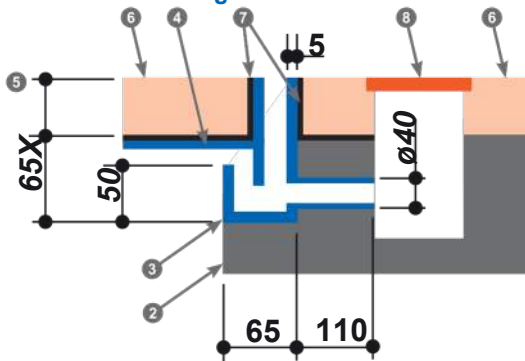

Notes :

- ① The slope of the drainage channel towards the entrance side. Inner wall of
- ② the lift shaft. Drainage channel will be provided by **Car Stackers**
- ③ **International** and to be installed by the customer.
- ④ Roof of the car lift.
- ⑤ Height of the flooring. The standard value of X = 50mm.
- ⑥ Flooring on the roof (max. 250 kg/m<sup>2</sup>) and surrounding to be performed by the customer. The total lifting capacity of the lift is including the vehicle to be lifted and the weight of the flooring on the roof of the lift.  
*For example:* if the max lifting capacity of the lift = 5000 kg, Car to be lifted (3000 kg) + the flooring weight on the roof of the lift (2000 kg) should not exceed 5000 kg.
- ⑦ Waterproofing on the roof and lift shaft to be performed by the customer.
- ⑧ Surrounding drainage channel with connection to sewerage system to be performed by the customer.

Page 1  
Specification, Variants and Dimensions

Page 2  
Lift position, Lift with garage door, Approach

Page 3  
Drainage plan, Detail building construction

Page 4  
Loadplan, Electrical installation

Page 5  
Technical hints

Page 6  
Facilities from customer

Page 7  
Description

► Detail building construction – Hydraulic & Electric unit

The room where to place the hydraulic unit and the electric control panel will be positioned must be chosen carefully and must be easily accessible from the outside. It is recommended that this room be closed with its own door with a key.

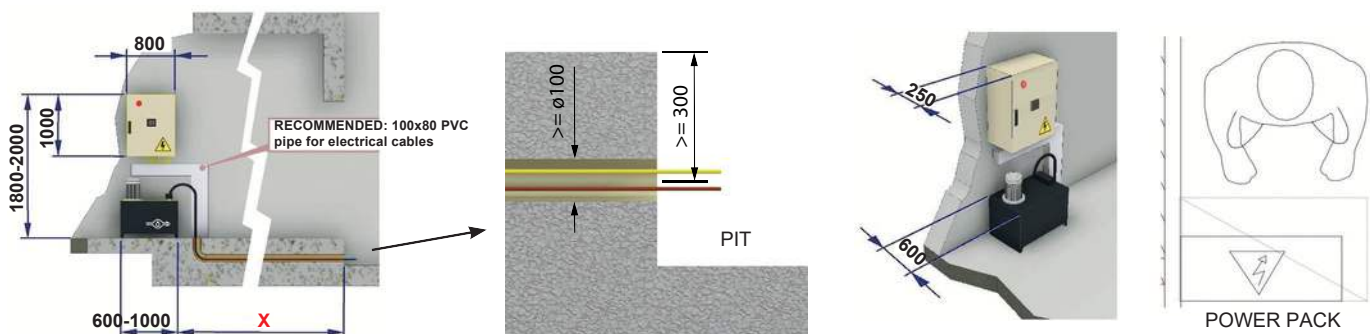

- The room chosen must have adequate ventilation to allow the electric motor to dissipate the heat produced during operation (< 50°C).
- Arrange plastic ducts as indicated for containing all the electrical cables coming from the pit compartment, push-button panels, doors etc.
- The pit must be connected to the electrical panel with 2 separate pipes with a minimum diameter of 100 mm to allow the passage of electric cables and hydraulic hoses. Avoid 90° bends in the pipes.
- When positioning the electrical panel and the hydraulic power unit, consider the measures indicated and provide sufficient space in front of it to ensure easy maintenance.

► **Load plan**

- The car lift are anchored into the side walls and ground. The drill hole depth on the floor is approx. 15 cm, and on the walls approx. 12 cm.
- Floor and walls below the drive-in level must be made of concrete (concrete quality min. C20/25)! The dimensions of the load-bearing points are approximate. If the exact dimensions are required, please consult Car Stackers Evolution

**Section view**

**Top view**

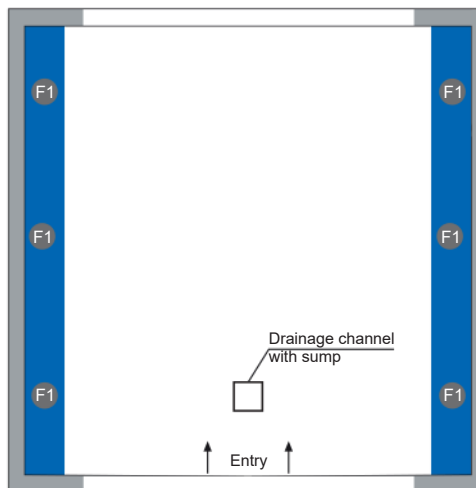
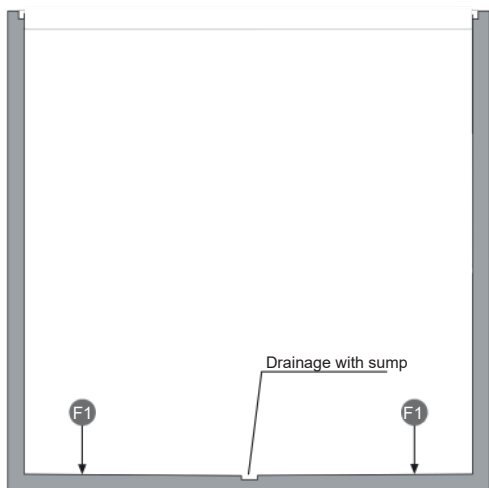

Force (kN)
F1
+70

► **Electrical installation**

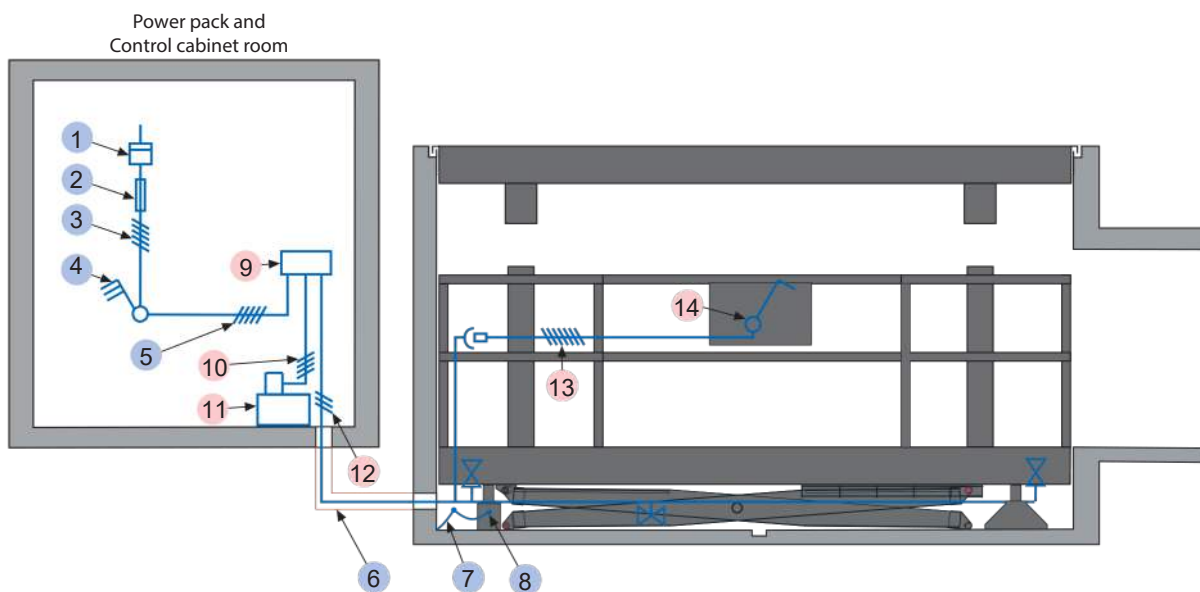

**Electrical data** to be performed by the customer

No.	Qty.	Description	Postion
1	1	Electricity meter	in the supply line in the supply line to
2	1	Main fuse : 3 x fuse 32 A (slow) or circuit breaker 3 x 32 A (trigger characteristic K, G or C)	main switch defined at the plan
3	1	Supply line 5 x 2.5 mm <sup>2</sup> (3 PH + N + PE) with marked wire and protective conductor	check from main switch to unit from
4	1	Lockable main switch	power pack and control cabinet
5	1	Supply line 5 x 2,5 mm <sup>2</sup> (3 PH + N + PE) with marked wire and protective conductor	corner of pit floor
6	2	Min. ø100 pipe	to pit floor
7	every 10 m	Foundation earth connector	
8	1	Potential equalization from foundation grounding connection system according to DIN EN 60204	

**Electrical data**

No.	Designation
9	Junction box unit
10	Control line 4 x 2,5 mm <sup>2</sup> with marked wire and protective conductor
11	Hydraulic unit 5.2 kW / 11 kW, three phase current, 230/400 V, 50 Hz
12	Control line 3 x 1 mm <sup>2</sup> (PH + N + PE)
13	Control line 4 x 1 mm <sup>2</sup> with marked wire and protective conductor
14	Operating device

## ► Technical hint

### Usage area

The system is suitable for outdoor installation and to lift heavy and large cars with a driver on board. The car lift is suitable for residential as well as office buildings. Feel free to contact **Car Stackers Evolution** for consultation.

### Units

Low-noise hydraulic units are installed. We also recommend separating the garage body from the residential building. The hydraulic unit and the electrical components must be housed in a cabinet (see “**Detail building construction – Hydraulic & Electric unit**”, page 3).

### CE certification

The systems offered correspond to the EC Machinery Directive 2006/42/CE.

### Building application documents

According to the EC Machinery Directive 2006/42/CE, the **Car Lift** systems are subject to approval. Please observe the local rules and regulations.

### Available documents

- Wall recess plans
- Maintenance offer / contract
- Declaration of conformity

### Environmental conditions

Ambient conditions for the areas around car lift systems:

- Temperature range -10 °C to +40 °C
- Relative humidity of 50% at a maximum outside temperature of +40 °C.

The lifting and lowering of the car lift are calculated at an ambient temperature of +10 °C and with the hydraulic system positioned immediately adjacent to the car lift. The operating time of car lift increases at lower ambient temperatures or with longer hydraulic lines.

### Care & Protection

To avoid corrosion damage, please follow separate cleaning and care instructions (as per the “**Corrosion protection**” sheet) and ensure that your garage is well ventilated.

### Noise protection

#### Standard noise protection:

As per DIN 4109-1 (Sound insulation in buildings – Part 1: Minimum requirements) - Section 9:

- Maximum noise level in living and sleeping areas 30 dB (A). Noise created by users are not considered.

The following dimensions are required for adherence to this value:

- Noise protection package in accordance with quote/order (**Car Stackers Evolution**).
- Noise insulation dimension of the building structure of minimum weighted sound reduction index, min.  $R'w = 57$  dB (service to be provided by the customer)

#### Increased noise protection (special agreement):

As per DIN 4109-5 (Sound insulation in buildings - Part 5: Increased requirements) - Section 8:

- Maximum noise pressure level in living and sleeping areas 25 dB (A). Noise created by users are not considered.

The following dimensions are required for adherence to this value:

- Noise protection package in accordance with quote/order (**Car Stackers Evolution**).
- Noise insulation dimension of the building structure of min.  $R'w = 62$  dB (service to be provided by the customer)

**HINT** : User noises are the noises that can be influenced by individual users of our **Car Lift** systems. These are created during the accessing of the platform, slamming of vehicle doors, engine, and brake noise.

Page 1  
Specification,  
Variants and  
Dimensions

Page 2  
Lift position,  
Lift with  
garage door,  
Approach

Page 3  
Drainage  
plan, Detail  
building  
construction

Page 4  
Loadplan,  
Electrical  
installation

Page 5  
Technical  
hints

Page 6  
Facilities from  
customer

Page 7  
Description

► **Facilities to be provided by the customer**

**Safety barriers**

During the car lift construction, in accordance with DIN EN ISO 13857, safety barriers are to be placed immediately in front of, adjacent to, or behind the systems where there are roadways.

**Building services**

Any lighting, ventilation, fire extinguishing and fire alarm systems, as well as clarification and compliance with the relevant regulatory requirements.

**Ventilation**

To ensure a continuous exchange of air, to reduce air humidity, prevent condensation and reduce vehicle moisture (from rain, snow, etc.), we recommend that the customer provide a ventilation system in conjunction with a specialist. This will help to minimise the risk of corrosion and resulting faults.

**Lighting**

The customer must observe local regulations pertaining to the illumination of parking spaces and roadways. In accordance with DIN EN 12464-1 'Light and lighting - Lighting of work places', an illumination level of min. 200 lx is recommended for the parking spaces and operating area of the system.

**Drainage**

A pump or drain sewerage is to be installed in the drainage sump (50 x 50 x 20 cm) inside the pit to avoid stagnant water (Component defect due to stagnant water will no longer be covered under warranty). For reasons of environmental protection, we recommend painting the pit floor, and to provide oil and petrol separators in the connections to the public sewage network.

**Electrical supply to the main switch / Foundation earth connector**

The customer must lay the supply cable to the master switch during assembly. Functional capability can be checked by our engineers on-site, in conjunction with the electrical engineer. If this is not possible during assembly for reasons attributable to the customer, the customer must commission an electrical engineer. The customer must earth the steel structure with a foundation earth connection (earthing distance max. 10 m) and equipotential bonding in accordance with DIN EN 60204 (see "Electrical installation", page 4)

**Control panel**

Empty conduits and recesses for the operating element (see "Electrical installation", page 4). Consultation with **Car Stackers Evolution** is required when using folding doors.

**Control panel on plaster**

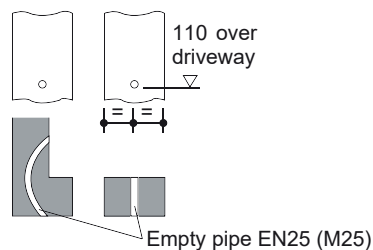

**If the following are not included in the quotation, they will also have to be provided/paid for by the customer:**

- Mounting of contactor and terminal box to the wall valve, complete wiring of all elements in accordance with the circuit diagram
- Costs for final technical approval by an authorized body
- Main switch
- Control line from main switch to hydraulic unit
- Railing

**Page 1**  
Specification,  
Variants and  
Dimensions

**Page 2**  
Lift position,  
Lift with  
garage door,  
Approach

**Page 3**  
Drainage  
plan, Detail  
building  
construction

**Page 4**  
Loadplan,  
Electrical  
installation

**Page 5**  
Technical  
hints

**Page 6**  
Facilities from  
customer

**Page 7**  
Description

## ► Description - Car lift with driver on board

### General description

- **The Car Lift systems** are for lifting heavy and large cars with a driver on board. The upper platform or roof may be used as a parking space under specific conditions.
- Dimensions according to the underlying pit, width and height dimensions.
- Passenger car positioning on car lift by means of positioning sensors on both sides (to be set in accordance with the operating instructions).
- Operation via a control element with Dead man's switch.
- Fixing the control element usually in front of the entrance or on the way revealing the outside.
- Operating instructions at every operating point.
- For car lifts with an entrance door, special dimensions must be respected.

### Car Lift system consisting of:

- 2 Rigid bases with foundation (fixed to the floor)
- 5 Hydraulic cylinders
- 1 Lower platform
- 1 Upper platform or Roof
- 4 support pillars for the roof
- 4 scissor members
- 6 support beams for scissor members
- 4 / 8 Nylon guide rollers
- Dowels, screws, fasteners, connecting elements etc.

### Platform consisting of:

- Checker plates
- Side fence
- Crossbeams
- Lateral beams
- Brackets
- Screws, nuts, etc.

### Hydraulics consisting of:

- Hydraulic cylinders
- Solenoid valve
- Safety valves
- Hydraulic lines
- Hydraulic fittings
- High-pressure hoses
- Mounting material

### Electrical system consisting of:

- 2 Operating elements (Emergency-stop, lock, access via RFID)
- Upto 4 safety light curtains for edge control
- Junction box unit
- Control cabinet

### Hydraulic unit consisting of:

- Hydraulic oil tank
- Oil filling
- Internal gear pump
- Pump holder
- Coupling
- Three-phase motor (5.2 kW / 11 kW, 230/400 V, 50 Hz, low noise)
- Pressure gauge
- Pressure relief valve
- Hydraulic hoses (to reduce noise transmission to the hydraulic pipes)

### We reserve the right to change these specifications without notice!

**Car Stackers Evolution** reserves the right, in the course of technical and technological progress, to use newer or different technologies, systems, processes, procedures, or standards than those originally offered and ensure that the customer does not incur any disadvantage.

#### Page 1

Specification, Variants and Dimensions

#### Page 2

Lift position, Lift with garage door, Approach

#### Page 3

Drainage plan, Detail building construction

#### Page 4

Loadplan, Electrical installation

#### Page 5

Technical hints

#### Page 6

Facilities from customer

#### Page 7

Description