

RISE-C

► Carlift

► Specification

- Stroke = up to 11000 mm
- Platform length = up to 6000 mm
- Platform width = up to 3500 mm
- Lifting capacity = up to 3000 kg
- Estimated speed = 7 to 10 cm/sec

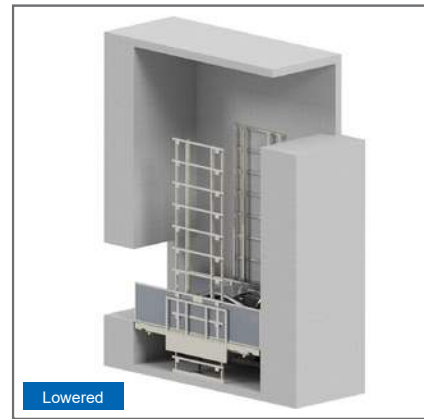
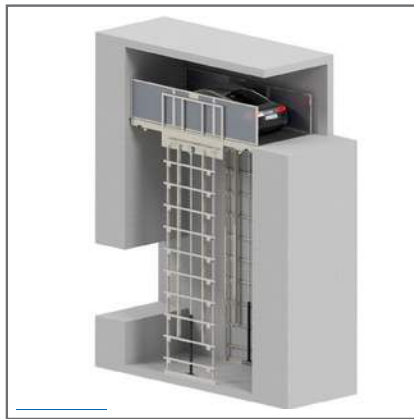

► Model with driver on board

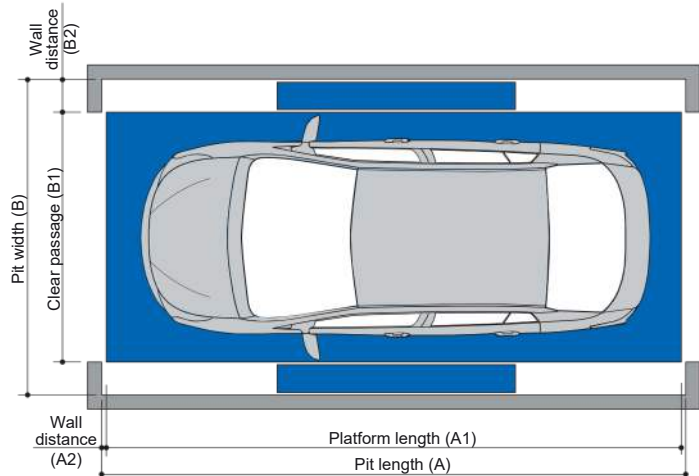
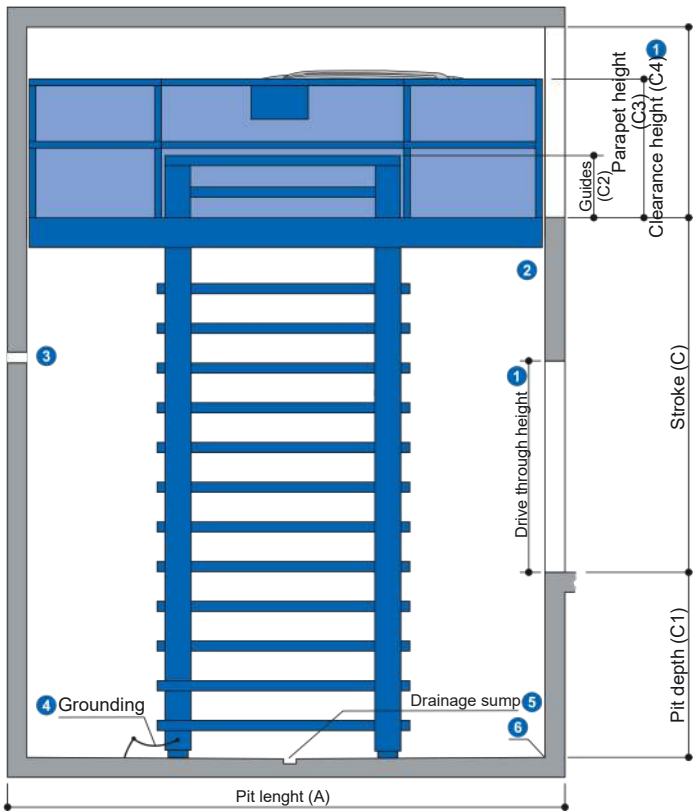

Parameter	Standard (mm)	Max (mm)	
Pit length	A	5360	6000
Platform length	A1	5310	5950
Wall distance	A2	25	
Pit width	B	3000	3500
Clear passage	B1	2500	3000
Side dimension	B2	250	

Parameter	Standard (mm)	Max (mm)		
Stroke	Pit	C	3000	11000
depth	Guides	C1	300 to 1500	
Parapet height	C2	0 to 1200		
Clear passage	C3	1200	2100	
	C4	to be defined		

► Notes

- 1 Must be at least as high as the greatest car height + 5 cm.
- 2 To comply with the minimum finished dimensions of the lift shaft, tolerances for space requirements according to VOB, Part C (DIN 18330 and 18331) and DIN 18202 must also be considered. Dimensions are in cm.
- 3 Ventilation inside the lift shaft has to be provided by the customer and must conform to **AS 5124**.
- 4 Grounding of the system to be connected to the central grounding on-site (to be provided by the customer).
- 5 Drainage sump : 10 x 2 cm with 50 x 50 x 50 cm drainage pit, install a sump pump (refer to manufacturer's dimensions).
- 6 At the transition section between the pit floor and walls, no hollow mouldings/coves are possible. If hollow mouldings/coves are required, the systems must be designed smaller or the pits accordingly wider.

Page1
Specification,
Variants and
Dimensions

Page2
Lift position,
Lift with
garage door,
Approach

Page3
Detail
building
construction,
Load plan

Page4
Electrical
installation

Page5
Technical
hints

Page6
Facilities from
customer

Page7
Description

► **Detail building construction – Hydraulic & Electric unit**

The room where to place the hydraulic unit and the electric control panel will be positioned must be chosen carefully and must be easily accessible from the outside. It is recommended that this room be closed with its own door with a key.

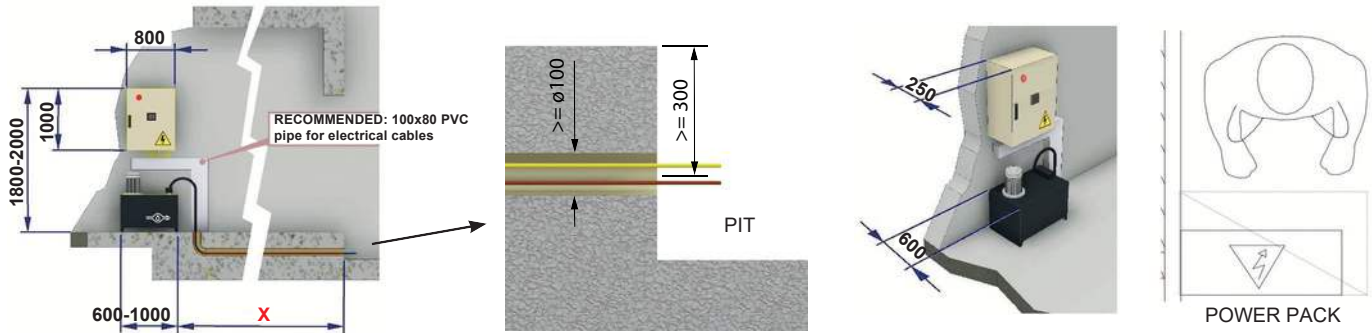

- The room chosen must have adequate ventilation to allow the electric motor to dissipate the heat produced during operation (< 50°C).
- Arrange plastic ducts as indicated for containing all the electrical cables coming from the pit compartment, push-button panels, doors etc.
- The pit must be connected to the electrical panel with 2 separate pipes with a minimum diameter of 100 mm to allow the passage of electric cables and hydraulic hoses. Avoid 90° bends in the pipes.
- When positioning the electrical panel and the hydraulic power unit, consider the measures indicated and provide sufficient space in front of it to ensure easy maintenance.

► **Load plan**

- The car lift are anchored into the side walls and ground. The drill hole depth on the floor is approx. 15 cm, and on the walls approx. 12 cm.
- Floor and walls below the drive-in level must be made of concrete (concrete quality min. C20/25)!
- The dimensions of the load-bearing points are approximate. If the exact dimensions are required, please consult **CarStackersInternational**

Section view

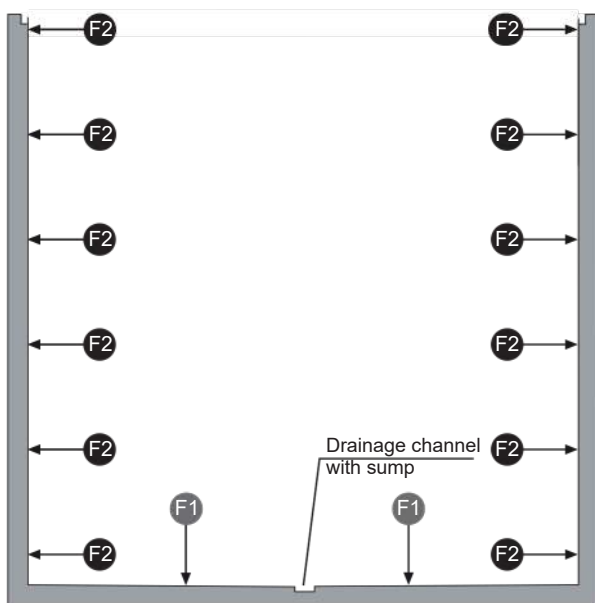

Top view

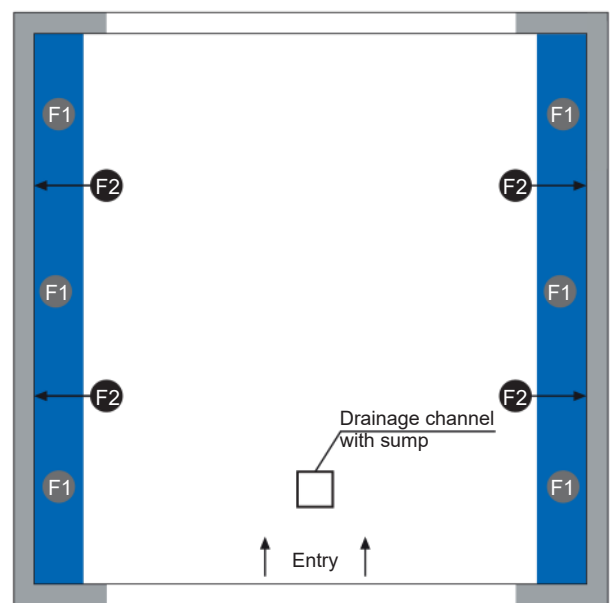

Force (kN)	
F1	F2
+35	-2

Page 1
Specification,
Variants and
Dimensions

Page 2
Lift position,
Lift with
garage door,
Approach

Page 3
Detail
building
construction,
Load plan

Page 4
Electrical
installation

Page 5
Technical
hints

Page 6
Facilities from
customer

Page 7
Description

► Lift position

System raised

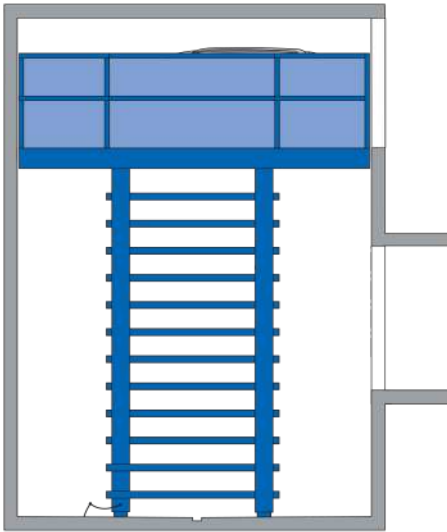

System lowered

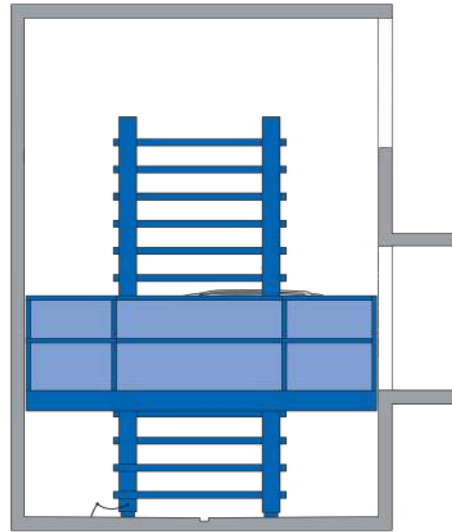

Page 1
Specification,
Variants and
Dimensions

Page 2
Lift position,
Lift with
garage door,
Approach

Page 3
Detail
building
construction,
Load plan

Page 4
Electrical
installation

Page 5
Technical
hints

Page 6
Facilities from
customer

Page 7
Description

► Lift with garage door

Sectional garage door

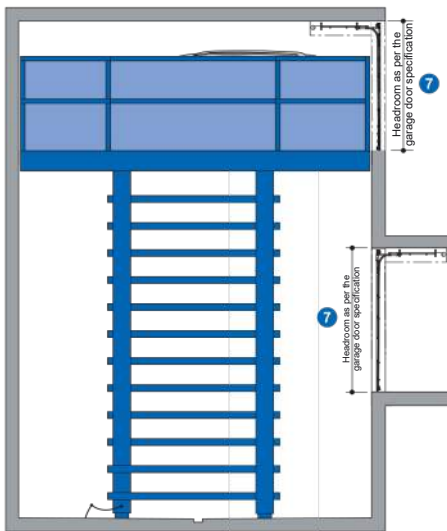

Roll-up garage door

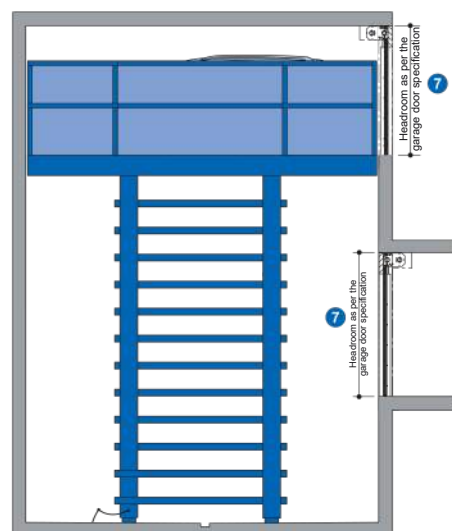

7 Dimensions for all doors must be coordinated with the door supplier. Coordination between the door manufacturer and **Car Stackers International** is necessary.

► Approach

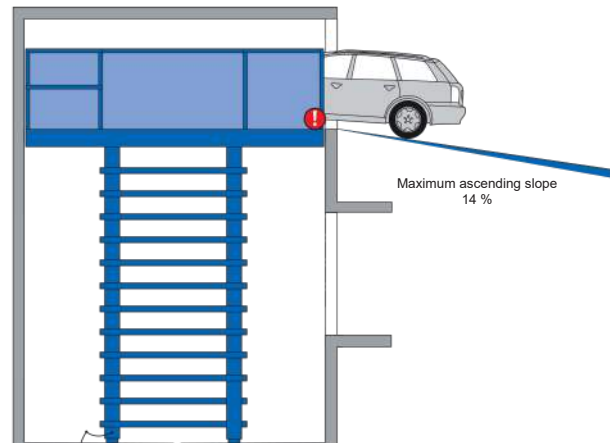
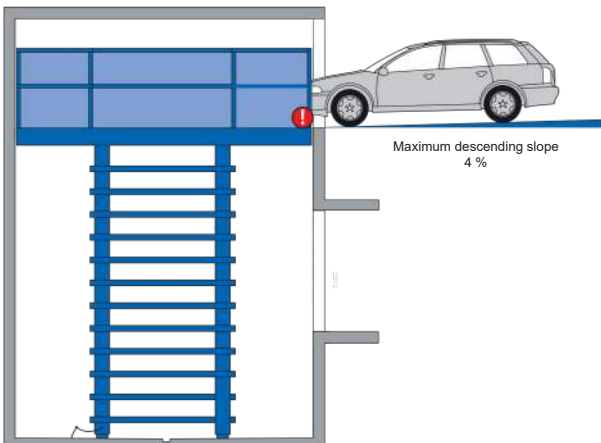

The illustrated maximum approach angles must not be exceeded. Incorrect approach angles will cause serious maneuvering and positioning problems on the parking system for which the company **Car Stackers Evolution** accepts no responsibility.

► **Electrical installation**

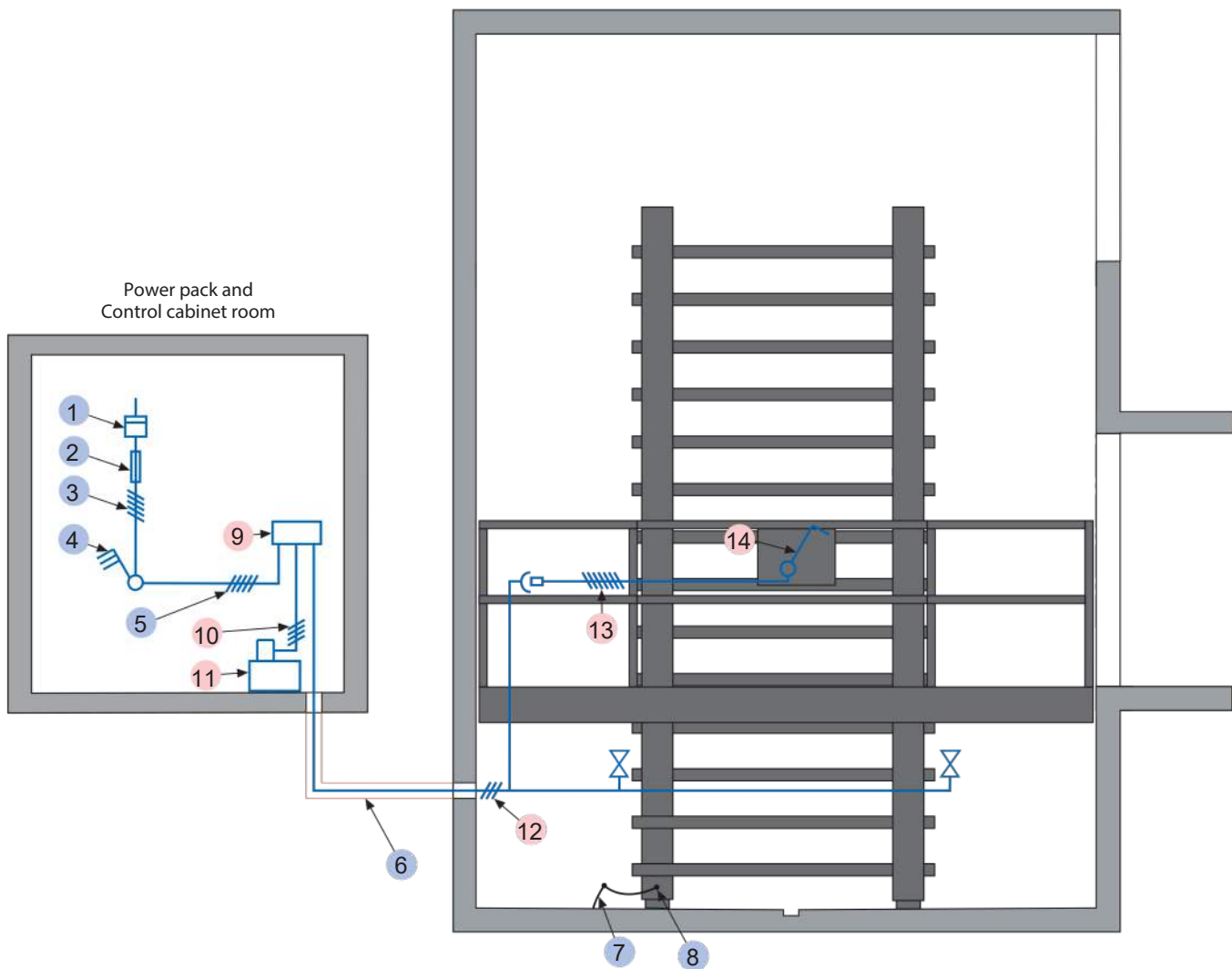

Electrical data to be performed by the customer

No.	Qty.	Description	Postion
1	1	Electricity meter	in the supply line in the supply line to
2	1	Main fuse : 3 x fuse 32 A (slow) or circuit breaker 3 x 32 A (trigger characteristic K, G or C)	main switch defined at the plan
3	1	Supply line 5 x 2,5 mm ² (3 PH + N + PE) with marked wire and protective conductor	check from main switch to unit from
4	1	Lockable main switch	power pack and control cabinet
5	1	Supply line 5 x 2,5 mm ² (3 PH + N + PE) with marked wire and protective conductor	corner of pit floor
6	2	Min. ø100 pipes	to pit floor
7	every 10 m	Foundation earth connector	
8	1	Potential equalization from foundation grounding connection system according to DIN EN 60204	

Electrical data

No.	Designation
9	Junction box unit
10	Control line 4 x 2,5 mm ² with marked wire and protective conductor
11	Hydraulic unit 5.2 kW / 11 kW, three phase current, 230/400 V, 50 Hz
12	Control line 3 x 1 mm ² (PH + N + PE)
13	Control line 4 x 1 mm ² with marked wire and protective conductor
14	Operating device

age1
pecification,
ariants and
imensions

age2
ift position,
ift with
arage door,
pproach

age3
etail
uilding
onstruction,
oad plan

age4
lectrical
stallation

age5
echnical
ints

age6
acilities from
ustomer

age7
escription

► Technical hint

Usage area

The system is suitable for indoor installation and to lift cars with a driver on board. The car lift is suitable for residential as well as office buildings. Feel free to contact **Car Stackers International** for consultation.

Units

Low-noise hydraulic units are installed. We also recommend separating the garage body from the residential building. The hydraulic unit and the electrical components must be housed in a cabinet (see “**Detail building construction – Hydraulic & Electric unit**”, page 3).

CE certification

The systems offered correspond to the EC Machinery Directive 2006/42/CE.

Building application documents

According to the EC Machinery Directive 2006/42/CE, the **Car Lift** systems are subject to approval. Please observe the local rules and regulations.

Available documents

- Wall recess plans
- Maintenance offer / contract
- Declaration of conformity

Environmental conditions

Ambient conditions for the areas around car lift systems:

- Temperature range -10 °C to +40 °C
- Relative humidity of 50% at a maximum outside temperature of +40 °C.

The lifting and lowering of the car lift are calculated at an ambient temperature of +10 °C and with the hydraulic system positioned immediately adjacent to the car lift. The operating time of car lift increases at lower ambient temperatures or with longer hydraulic lines.

Care & Protection

To avoid corrosion damage, please follow separate cleaning and care instructions (as per the “**Corrosion protection**” sheet) and ensure that your garage is well ventilated.

Noise protection

Standard noise protection:

As per DIN 4109-1 (Sound insulation in buildings – Part 1: Minimum requirements) - Section 9:

- Maximum noise level in living and sleeping areas 30 dB (A).
Noise created by users are not considered.

The following dimensions are required for adherence to this value:

- Noise protection package in accordance with quote/order with (**Car Stackers International**).
- Noise insulation dimension of the building structure of minimum weighted sound reduction index, min. $R'w = 57$ dB (service to be provided by the customer)

Increased noise protection (special agreement):

As per DIN 4109-5 (Sound insulation in buildings - Part 5: Increased requirements) - Section 8: ■ Maximum noise pressure level in living and sleeping areas 25 dB (A). Noise created by users are not considered.

The following dimensions are required for adherence to this value:

- Noise protection package in accordance with quote/order with (**Car Stackers**).
- Noise insulation dimension of the building structure of min. $R'w = 62$ dB (service to be provided by the customer)

HINT : User noises are the noises that can be influenced by individual users of our **Car Lift** systems. These are created during the accessing of the platform, slamming of vehicle doors, engine, and brake noise.

Page 1
Specification,
Variants and
Dimensions

Page 2
Lift position,
Lift with
garage door,
Approach

Page 3
Detail
building
construction,
Load plan

Page 4
Electrical
installation

Page 5
Technical
hints

Page 6
Facilities from
customer

Page 7
Description

► **Facilities to be provided by the customer**

Safety barriers

During the car lift construction, in accordance with DIN EN ISO 13857, safety barriers are to be placed immediately in front of, adjacent to, or behind the systems where there are roadways.

Building services

Any lighting, ventilation, fire extinguishing and fire alarm systems, as well as clarification and compliance with the relevant regulatory requirements.

Ventilation

To ensure a continuous exchange of air, to reduce air humidity, prevent condensation and reduce vehicle moisture (from rain, snow, etc.), we recommend that the customer provide a ventilation system in conjunction with a specialist. This will help to minimise the risk of corrosion and resulting faults.

Lighting

The customer must observe local regulations pertaining to the illumination of parking spaces and roadways. In accordance with DIN EN 12464-1 'Light and lighting - Lighting of work places', an illumination level of min. 200 lx is recommended for the parking spaces and operating area of the system.

Drainage

A pump or drain sewerage is to be installed in the drainage sump (50 x 50 x 20 cm) inside the pit to avoid stagnant water (Component defect due to stagnant water will no longer be covered under warranty). For reasons of environmental protection, we recommend painting the pit floor, and to provide oil and petrol separators in the connections to the public sewage network.

Electrical supply to the main switch / Foundation earth connector

The customer must lay the supply cable to the main switch during assembly. Functional capability can be checked by our engineers on-site, in conjunction with the electrical engineer. If this is not possible during assembly for reasons attributable to the customer, the customer must commission an electrical engineer.

The customer must earth the steel structure with a foundation earth connection (earthing distance max. 10 m) and equipotential bonding in accordance with DIN EN 60204 (see "Electrical installation", page 4)

Control panel

Empty conduits and recesses for the operating element (see "Electrical installation", page 4). Consultation with **Car Stackers International** is required when using folding doors.

Control panel on plaster

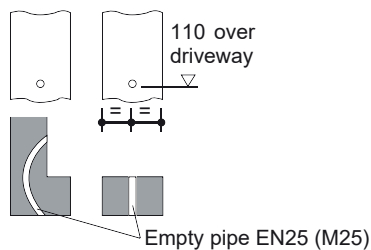

If the following are not included in the quotation, they will also have to be provided/paid for by the customer:

- Mounting of contactor and terminal box to the wall valve, complete wiring of all elements in accordance with the circuit diagram
- Costs for final technical approval by an authorized body
- Main switch
- Control line from main switch to hydraulic unit
- Railing

Page 1
Specification,
Variants and
Dimensions

Page 2
Lift position,
Lift with
garage door,
Approach

Page 3
Detail
building
construction,
Load plan

Page 4
Electrical
installation

Page 5
Technical
hints

Page 6
Facilities from
customer

Page 7
Description

► Description - Car lift with driver on board

General description

- The car lifts are for lifting cars with a driver on board.
- Dimensions according to the underlying pit, width and height dimensions.
- Passenger car positioning on car lift by means of positioning sensors on both sides (to be set in accordance with the operating instructions).
- Operation via a control element with Dead man's switch.
- Fixing the control element usually in front of the entrance or on the way revealing the outside.
- Operating instructions at every operating point.
- For car lifts with an entrance door, special dimensions must be respected.

The Car Lift system consisting of:

- 2 Sidepillars or guide
- 2 / 4 Hydraulic cylinders
- 1 Platform
- 4 / 8 Nylon guide rollers
- Dowels, screws, fasteners, connecting elements etc.

Platform consisting of:

- Checker plates
- Side fence
- Crossbeams
- Lateral beams
- Brackets
- Screws, nuts, etc.

Hydraulics consisting of:

- Hydraulic cylinders
- Solenoid valve
- Safety valves
- Hydraulic lines
- Hydraulic fittings
- High-pressure hoses
- Mounting material

Electrical system consisting of:

- 2 Operating elements (Emergency-stop, lock, access via RFID)
- Upto 4 safety light curtains for edge control
- Junction box unit
- Control cabinet

Hydraulic unit consisting of:

- Hydraulic oil tank
- Oil filling
- Internal gear pump
- Pump holder
- Coupling
- Three-phase motor (5.2 kW / 11 kW, 230/400 V, 50 Hz, low noise)
- Pressure gauge
- Pressure relief valve
- Hydraulic hoses (to reduce noise transmission to the hydraulic pipes)

We reserve the right to change these specifications without notice!

CarStackersInternational reserves the right, in the course of technical and technological progress, to use newer or different technologies, systems, processes, procedures, or standards than those originally offered and ensure that the customer does not incur any disadvantage.

Page 1
Specification,
Variants and
Dimensions

Page 2
Lift position,
Lift with
garage door,
Approach

Page 3
Detail
building
construction,
Load plan

Page 4
Electrical
installation

Page 5
Technical
hints

Page 6
Facilities from
customer

Page 7
Description

RISE-P

► Carlift

► Specification

- Stroke = up to 3700 mm
- Platform length = up to 5950 mm
- Platform width = up to 2900 mm
- Lifting capacity = up to 3500 kg
- Estimated speed = 7 to 10 cm/sec

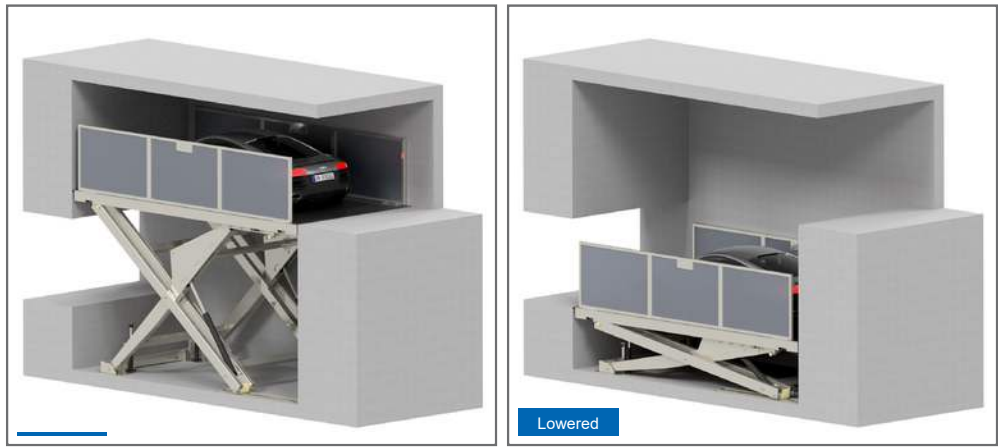

► Model with driver on board

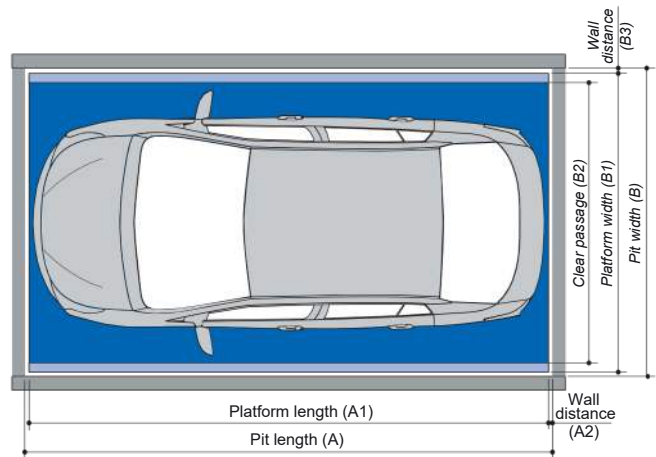
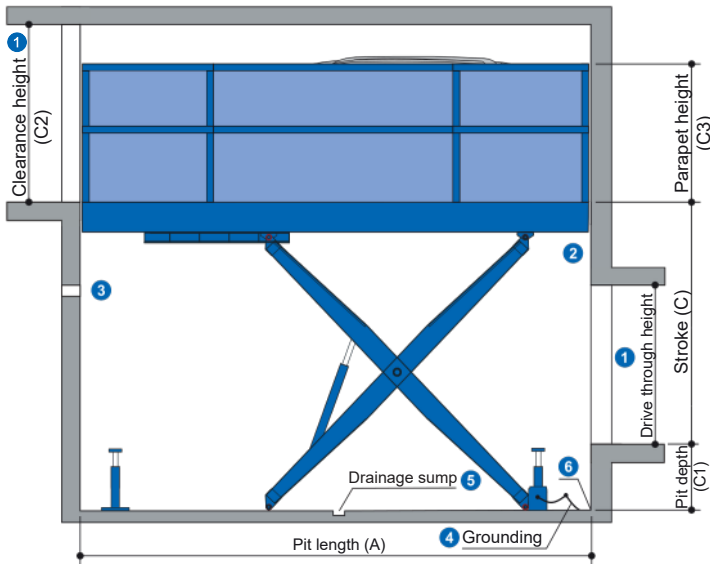

Parameter	Standard (mm)	Max (mm)
Pit length	A	5100 / 6000
Platform length	A1	5050 / 5950
Wall distance	A2	25
Pit width	B	2500 / 3000
Platform width	B1	2400 / 2900
Clear passage	B2	2300 / 2800
Wall distance	B3	50

Parameter	Standard (mm)	Max (mm)	
Stroke	Pit	C	2700 / 3700
depth	Clear	C1	550 to 650
passage	C2		to be defined
Parapet height	C3		1200 / 2100

► Notes

- 1 Must be at least as high as the greatest car height + 5 cm.
- 2 To comply with the minimum finished dimensions of the lift shaft, tolerances for space requirements σ_0 according to VOB, Part C (DIN 18330 and 18331) and DIN 18202 must also be considered. Dimensions are in cm.
- 3 Ventilation inside the lift shaft has to be provided by the customer and must conform to **AS 5124**.
- 4 Grounding of the system to be connected to the central grounding on-site (to be provided by the customer).
- 5 Drainage sump : 10 x 2 cm with 50 x 50 x 50 cm drainage pit, install a sump pump (refer to manufacturer's dimensions).
- 6 At the transition section between the pit floor and walls, no hollow mouldings/coves are possible. If hollow mouldings/coves are required, the systems must be designed smaller or the pits accordingly wider.

Page 1
Specification,
Variants and
Dimensions

Page 2
Lift position,
Lift with
garage door,
Approach

Page 3
Detail
building
construction,
Load plan

Page 4
Electrical
installation

Page 5
Technical
hints

Page 6
Facilities from
customer

Page 7
Description

► Lift position

System raised

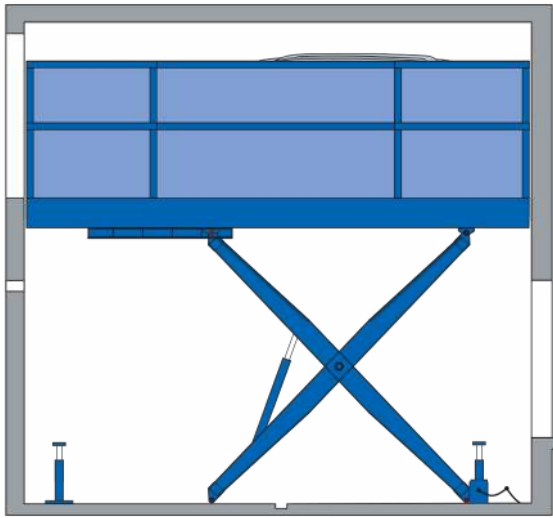

System lowered

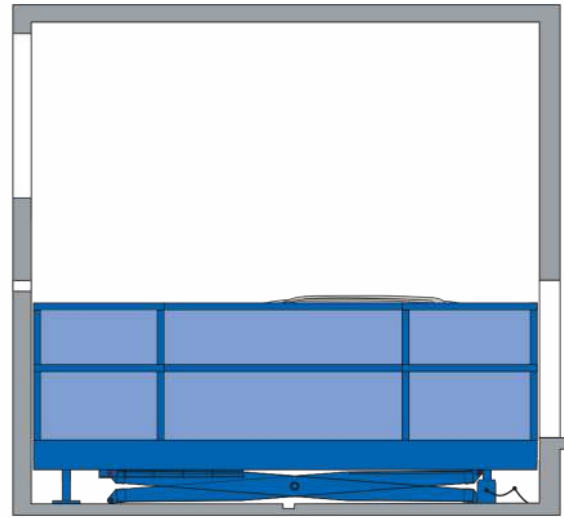

Page 1
Specification,
Variants and
Dimensions

Page 2
Lift position,
Lift with
garage door,
Approach

Page 3
Detail
building
construction,
Load plan

Page 4
Electrical
installation

► Lift with garage door

Sectional garage door

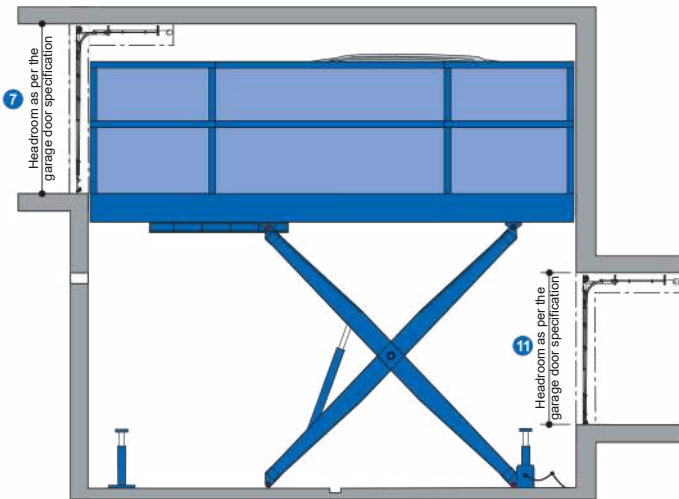

Roll-up garage door

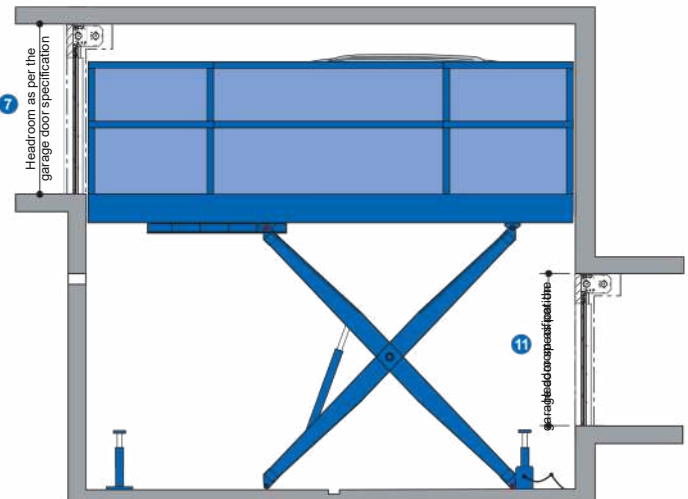

Page 5
Technical
hints

Page 6
Facilities from
customer

Page 7
Description

7 Dimensions for all doors must be coordinated with the door supplier. Coordination between the door manufacturer and **Car Stackers International** is necessary.

► Approach

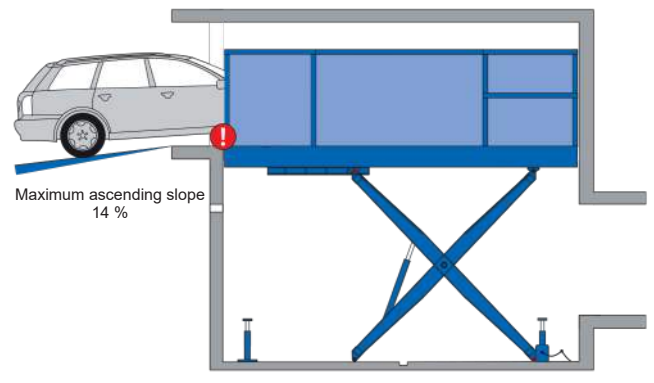
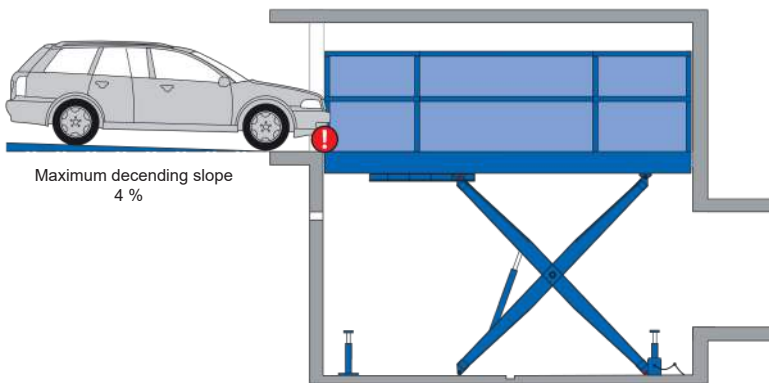

The illustrated maximum approach angles must not be exceeded. Incorrect approach angles will cause serious maneuvering and positioning problems on the parking system for which the company **Car Stackers** accepts no responsibility.

► **Detail building construction – Hydraulic & Electric unit**

The room where to place the hydraulic unit and the electric control panel will be positioned must be chosen carefully and must be easily accessible from the outside. It is recommended that this room be closed with its own door with a key.

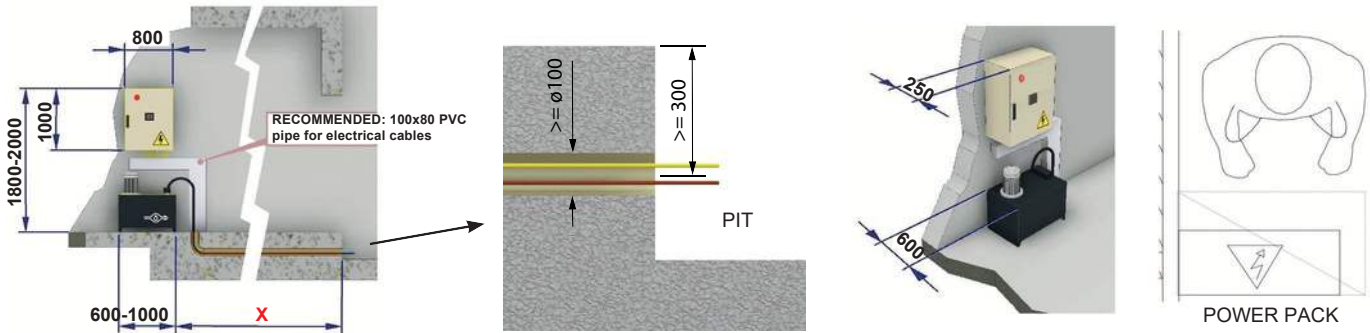

- The room chosen must have adequate ventilation to allow the electric motor to dissipate the heat produced during operation (< 50°C).
- Arrange plastic ducts as indicated for containing all the electrical cables coming from the pit compartment, push-button panels, doors etc.
- The pit must be connected to the electrical panel with 2 separate pipes with a minimum diameter of 100 mm to allow the passage of electric cables and hydraulic hoses. Avoid 90° bends in the pipes.
- When positioning the electrical panel and the hydraulic power unit, consider the measures indicated and provide sufficient space in front of it to ensure easy maintenance.

► **Load plan**

- The car lift are anchored into the side walls and ground. The drill hole depth on the floor is approx. 15 cm, and on the walls approx. 12 cm.
- Floor and walls below the drive-in level must be made of concrete (concrete quality min. C20/25)!
- The dimensions of the load-bearing points are approximate. If the exact dimensions are required, please consult **CarStackersInternational**.

Section view

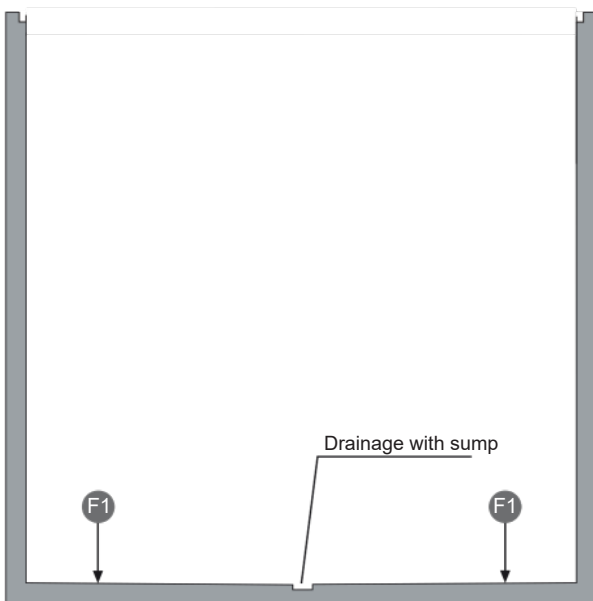

Top view

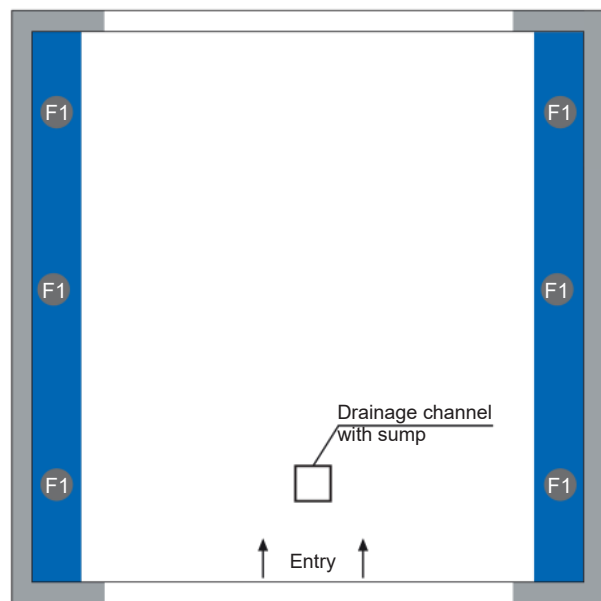

Force (kN)
F1
+35

Page 1
Specification,
Variants and
Dimensions

Page 2
Lift position,
Lift with
garage door,
Approach

Page 3
Detail
building
construction,
Load plan

Page 4
Electrical
installation

Page 5
Technical
hints

Page 6
Facilities from
customer

Page 7
Description

► **Electrical installation**

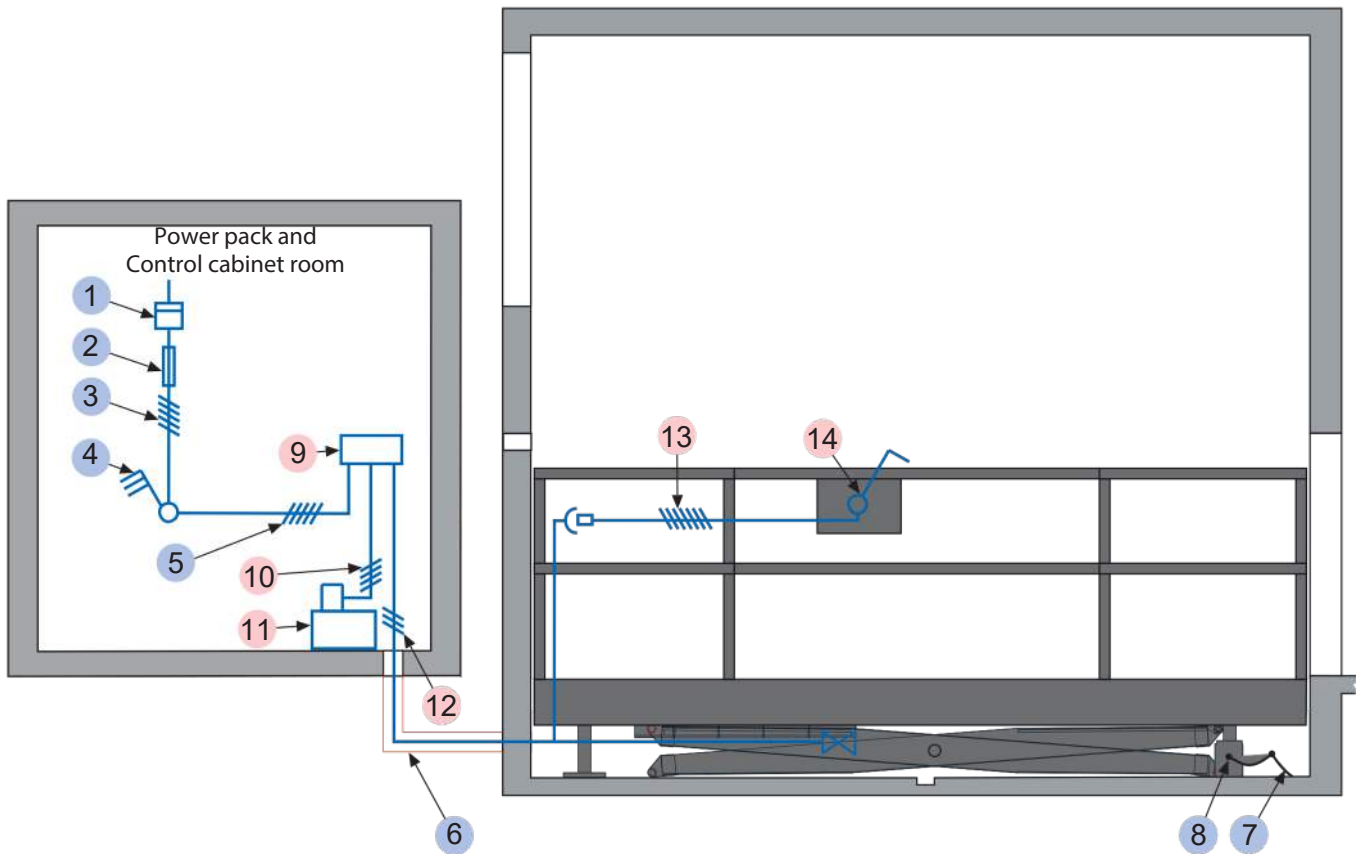

Page1
Specification,
Variants and
Dimensions

Page2
Lift position,
Lift with
garage door,
Approach

Page3
Detail
building
construction,
Load plan

Page4
Electrical
installation

Page5
Technical
hints

Page6
Facilities from
customer

Page7
Description

Electrical data to be performed by the customer

No.	Qty.	Description	Postion
1	1	Electricity meter	in the supply line in the supply line to
2	1	Main fuse : 3 x fuse 32 A (slow) or circuit breaker 3 x 32 A (trigger characteristic K, G or C)	main switch defined at the plan
3	1	Supply line 5 x 2.5 mm ² (3 PH + N + PE) with marked wire and protective conductor	check from main switch to unit from
4	1	Lockable main switch	power pack and control cabinet
5	1	Supply line 5 x 2.5 mm ² (3 PH + N + PE) with marked wire and protective conductor	corner of pit floor
6	2	Min. ø100 pipes	to pit floor
7	every 10 m	Foundation earth connector	
8	1	Potential equalization from foundation grounding connection system according to DIN EN 60204	

Electrical data

No.	Designation
9	Junction box unit
10	Control line 4 x 2,5 mm ² with marked wire and protective conductor
11	Hydraulic unit 5.2 kW / 11 kW, three phase current, 230/400 V, 50 Hz
12	Control line 3 x 1 mm ² (PH + N + PE)
13	Control line 4 x 1 mm ² with marked wire and protective conductor
14	Operating device

► Technical hint

Usage area

The system is suitable for indoor installation and to lift cars with a driver on board. The car lift is suitable for residential as well as office buildings. Feel free to contact **Car Stackers International** for consultation.

Units

Low-noise hydraulic units are installed. We also recommend separating the garage body from the residential building. The hydraulic unit and the electrical components must be housed in a cabinet (see “**Detail building construction – Hydraulic & Electric unit**”, page 3).

CE certification

The systems offered correspond to the EC Machinery Directive 2006/42/CE.

Building application documents

According to the EC Machinery Directive 2006/42/CE, the **Car Lift** systems are subject to approval. Please observe the local rules and regulations.

Available documents

- Wall recess plans
- Maintenance offer / contract
- Declaration of conformity

Environmental conditions

Ambient conditions for the areas around car lift systems:

- Temperature range -10 °C to +40 °C
- Relative humidity of 50% at a maximum outside temperature of +40 °C.

The lifting and lowering of the car lift are calculated at an ambient temperature of +10 °C and with the hydraulic system positioned immediately adjacent to the car lift. The operating time of car lift increases at lower ambient temperatures or with longer hydraulic lines.

Care & Protection

To avoid corrosion damage, please follow separate cleaning and care instructions (as per the “**Corrosion protection**” sheet) and ensure that your garage is well ventilated.

Noise protection

Standard noise protection:

As per DIN 4109-1 (Sound insulation in buildings – Part 1: Minimum requirements) - Section 9: ■ Maximum noise level in living and sleeping areas 30 dB (A). Noise created by users are not considered.

The following dimensions are required for adherence to this value:

- Noise protection package in accordance with quote/order (**Car Stackers**).
- Noise insulation dimension of the building structure of minimum weighted sound reduction index, min. $R'w = 57$ dB (service to be provided by the customer)

Increased noise protection (special agreement):

As per DIN 4109-5 (Sound insulation in buildings - Part 5: Increased requirements) - Section 8: ■ Maximum noise pressure level in living and sleeping areas 25 dB (A). Noise created by users are not considered.

The following dimensions are required for adherence to this value:

- Noise protection package in accordance with quote/order (**Car Stackers**).
- Noise insulation dimension of the building structure of min. $R'w = 62$ dB (service to be provided by the customer)

HINT : User noises are the noises that can be influenced by individual users of our **Car Lift** systems. These are created during the accessing of the platform, slamming of vehicle doors, engine, and brake noise.

Page 1
Specification,
Variants and
Dimensions

Page 2
Lift position,
Lift with
garage door,
Approach

Page 3
Detail
building
construction,
Load plan

Page 4
Electrical
installation

Page 5
Technical
hints

Page 6
Facilities from
customer

Page 7
Description

► **Facilities to be provided by the customer**

Safety barriers

During the car lift construction, in accordance with DIN EN ISO 13857, safety barriers are to be placed immediately in front of, adjacent to, or behind the systems where there are roadways.

Building services

Any lighting, ventilation, fire extinguishing and fire alarm systems, as well as clarification and compliance with the relevant regulatory requirements.

Ventilation

To ensure a continuous exchange of air, to reduce air humidity, prevent condensation and reduce vehicle moisture (from rain, snow, etc.), we recommend that the customer provide a ventilation system in conjunction with a specialist. This will help to minimise the risk of corrosion and resulting faults.

Lighting

The customer must observe local regulations pertaining to the illumination of parking spaces and roadways. In accordance with DIN EN 12464-1 'Light and lighting - Lighting of work places', an illumination level of min. 200 lx is recommended for the parking spaces and operating area of the system.

Drainage

A pump or drain sewerage is to be installed in the drainage sump (50 x 50 x 20 cm) inside the pit to avoid stagnant water (Component defect due to stagnant water will no longer be covered under warranty). For reasons of environmental protection, we recommend painting the pit floor, and to provide oil and petrol separators in the connections to the public sewage network.

Electrical supply to the main switch / Foundation earth connector

The customer must lay the supply cable to the main switch during assembly. Functional capability can be checked by our engineers on-site, in conjunction with the electrical engineer. If this is not possible during assembly for reasons attributable to the customer, the customer must commission an electrical engineer.

The customer must earth the steel structure with a foundation earth connection (earthing distance max. 10 m) and equipotential bonding in accordance with DIN EN 60204 (see "Electrical installation", page 4)

Control panel

Empty conduits and recesses for the operating element (see "Electrical installation", page 4). Consultation with **Car Stackers Evolution** is required when using folding doors.

Control panel on plaster

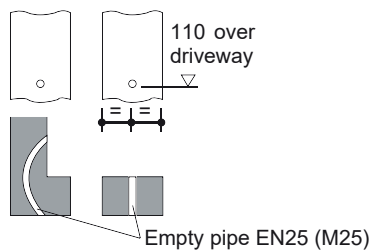

If the following are not included in the quotation, they will also have to be provided/paid for by the customer:

- Mounting of contactor and terminal box to the wall valve, complete wiring of all elements in accordance with the circuit diagram
- Costs for final technical approval by an authorized body
- Main switch
- Control line from main switch to hydraulic unit
- Railing

Page 1
Specification,
Variants and
Dimensions

Page 2
Lift position,
Lift with
garage door,
Approach

Page 3
Detail
building
construction,
Load plan

Page 4
Electrical
installation

Page 5
Technical
hints

Page 6
Facilities from
customer

Page 7
Description

► Description - Car lift with driver on board

General description

- The car lifts are for lifting cars with a driver on board.
- Dimensions according to the underlying pit, width and height dimensions.
- Passenger car positioning on car lift by means of positioning sensors on both sides (to be set in accordance with the operating instructions).
- Operation via a control element with Dead man's switch.
- Fixing the control element usually in front of the entrance or on the way revealing the outside.
- Operating instructions at every operating point.
- For car lifts with an entrance door, special dimensions must be respected.

Car Lift system consisting of:

- 1 Rigid base with foundation (fixed to the floor)
- 2 Hydraulic cylinders
- 1 Platform
- 4 Scissor members
- 6 Support beams for scissor members
- 4 / 8 Nylon guide rollers
- Dowels, screws, fasteners, connecting elements etc.

Platform consisting of:

- Checker plates
- Side fence
- Crossbeams
- Lateral beams
- Brackets
- Screws, nuts, etc.

Hydraulics consisting of:

- Hydraulic cylinders
- Solenoid valve
- Safety valves
- Hydraulic lines
- Hydraulic fittings
- High-pressure hoses
- Mounting material

Electrical system consisting of:

- 2 Operating elements (Emergency-stop, lock, access via RFID)
- Upto 4 safety light curtains for edge control
- Junction box unit
- Control cabinet

Hydraulic unit consisting of:

- Hydraulic oil tank
- Oil filling
- Internal gear pump
- Pump holder
- Coupling
- Three-phase motor (5.2 kW / 11 kW, 230/400 V, 50 Hz, low noise)
- Pressure gauge
- Pressure relief valve
- Hydraulic hoses (to reduce noise transmission to the hydraulic pipes)

We reserve the right to change these specifications without notice!

CarStackers reserves the right, in the course of technical and technological progress, to use newer or different technologies, systems, processes, procedures, or standards than those originally offered and ensure that the customer does not incur any disadvantage.

Page 1
Specification,
Variants and
Dimensions

Page 2
Lift position,
Lift with
garage door,
Approach

Page 3
Detail
building
construction,
Load plan

Page 4
Electrical
installation

Page 5
Technical
hints

Page 6
Facilities from
customer

Page 7
Description

RISE-R-5-P

Carlift

Specification

- Stroke = up to 3700 mm
- Platform length = up to 6450 mm
- Platform width = up to 3000 mm
- Lifting capacity = up to 5000 kg ¹
- Estimated speed = 6 to 8 cm/sec



Model with driver on board

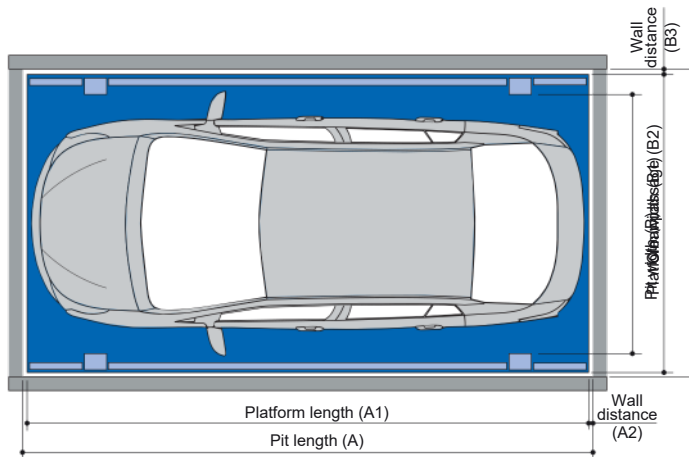
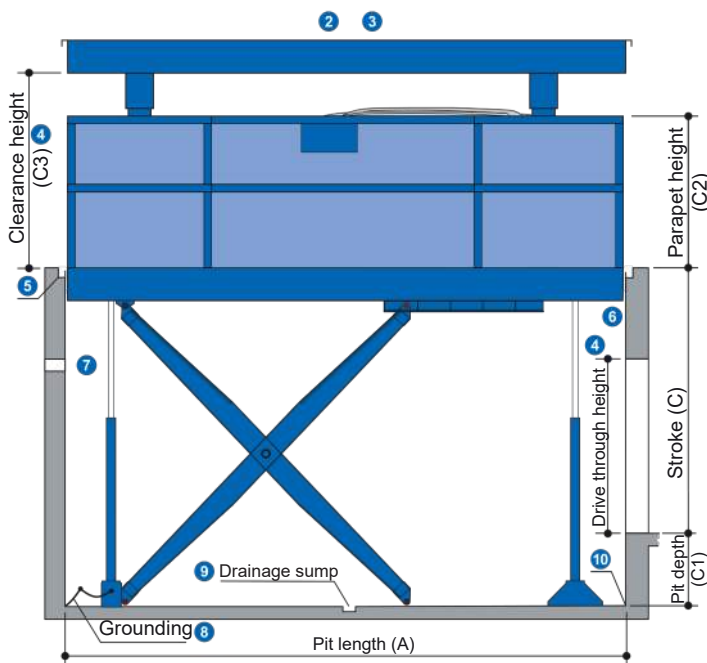

Parameter		Standard (mm)	Max (mm)
Pit length	A	5360	6500
Platform length	A1	5310	6450
Wall distance	A2	25	
Pit width	B	2500	3000
Platform width	B1	2450	2950
Clear passage	B2	2200	2700
Wall distance	B3	25	

Parameter		Standard (mm)	Max (mm)
Stroke	Pit	C	2700
depth	Parapet	C1	570 to 620
height	Clear	C2	1200
passage		C3	1800
			2200

Notes

- ¹ Lifting capacity of the lift = Car to be lifted + Flooring weight on the roof of the lift (max. 250 kg/m²).
For example: if the max lifting capacity of the lift = 5000 kg, Car to be lifted (3000 kg) + flooring weight on roof of the lift (2000 kg) should not exceed 5000 kg.
- ² For countries with snowfall, the excessive snow on the lift is to be cleared before operating.
- ³ During the lowered position of the lift, the roof of the lift can be considered as a parking space under specific conditions. The vehicle parked on the roof should be removed before operating the lift.
- ⁴ Must be at least as high as the greatest car height + 5 cm.
- ⁵ Surrounding drainage system with connection to sewerage system to be performed by the customer (see "Drainage plan", page 4).
- ⁶ To comply with the minimum finished dimensions of the lift shaft, tolerances for space requirements ⁺³/₀ according to VOB, Part C (DIN 18330 and 18331) and DIN 18202 must also be considered. Dimensions are in cm.
- ⁷ Ventilation inside the lift shaft has to be provided by the customer and must conform to **AS 5124**.
- ⁸ Grounding of the system to be connected to the central grounding on-site (to be provided by the customer).
- ⁹ Drainage sump : 10 x 2 cm with 50 x 50 x 50 cm drainage pit, install a sump pump (refer to manufacturer's dimensions).
- ¹⁰ At the transition section between the pit floor and walls, no hollow mouldings/coves are possible. If hollow mouldings/coves are required, the systems must be designed smaller or the pits accordingly wider.

► Lift position

System raised

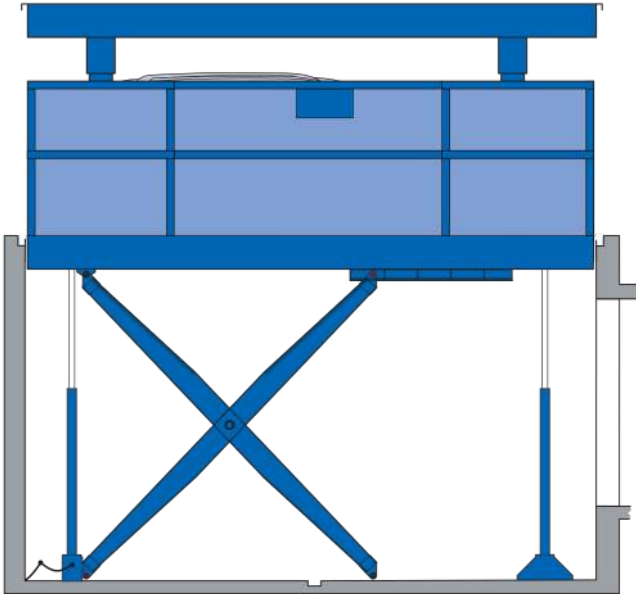

System lowered

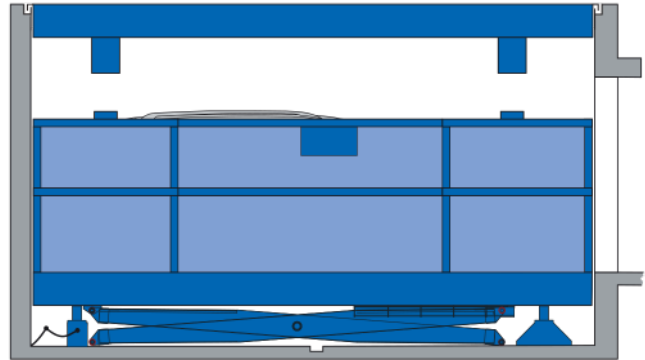

Page 1
Specification,
Variants and
Dimensions

Page 2
Lift position,
Lift with
garage door,
Approach

Page 3
Drainage
plan, Detail
building
construction

Page 4
Loadplan,
Electrical
installation

Page 5
Technical
hints

► Lift with garage door

Sectional garage door

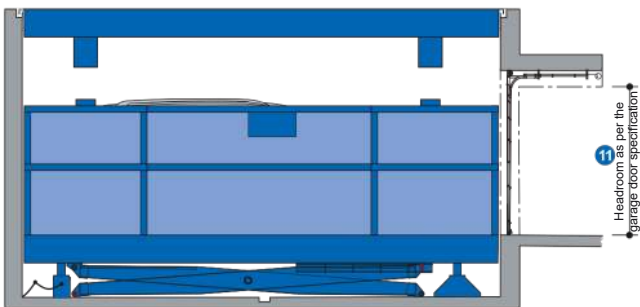

Roll-up garage door

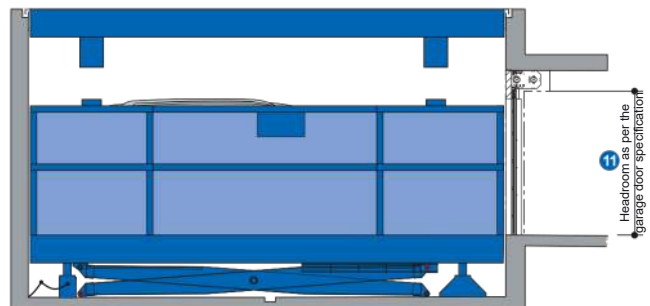

11 Dimensions for all doors must be coordinated with the door supplier. Coordination between the door manufacturer and **Car Stackers International** is necessary.

Page 6
Facilities from
customer

Page 7
Description

► Approach

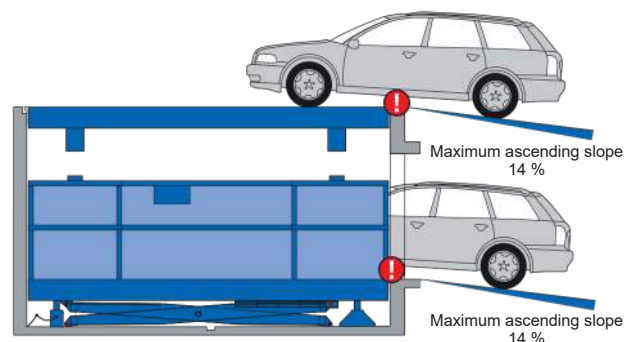
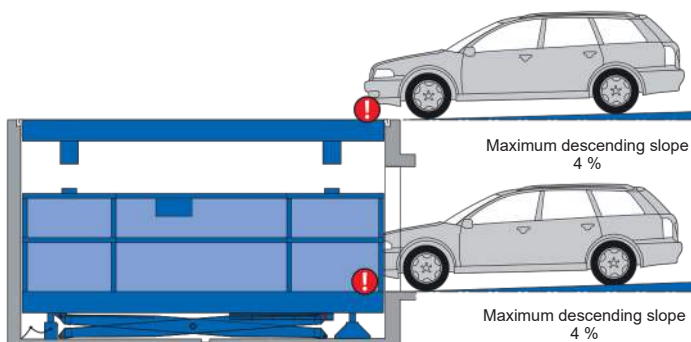

The illustrated maximum approach angles must not be exceeded. Incorrect approach angles will cause serious maneuvering and positioning problems on the parking system for which the company **Car Stackers** accepts no responsibility.

► Drainage plan

Overview of the pit

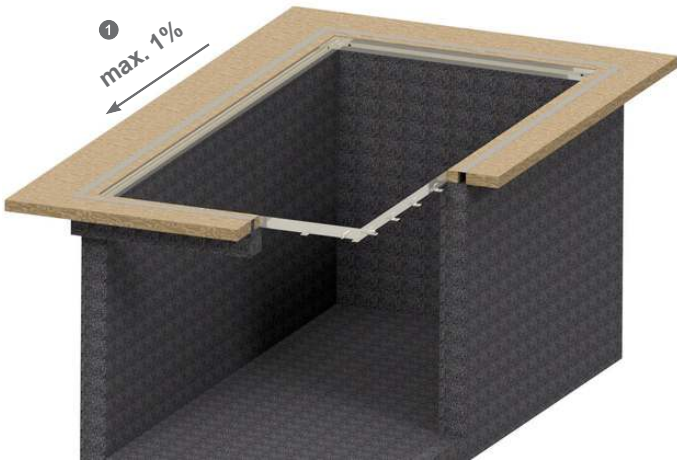

Section view of drainage channel

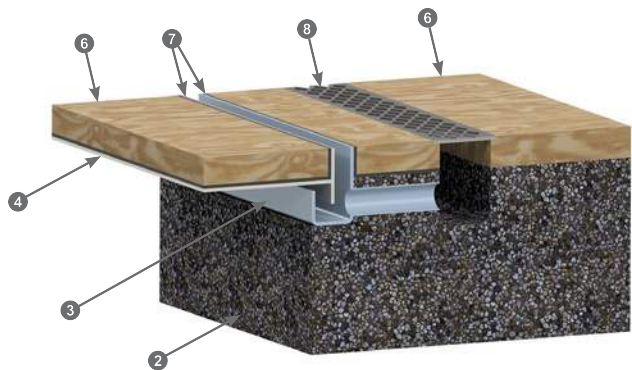

Section view of drainage channel

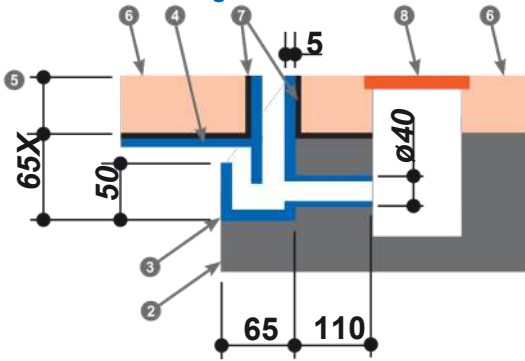

Notes :

- ① The slope of the drainage channel towards the entrance side. Inner wall of
- ② the lift shaft. Drainage channel will be provided by **Car Stackers**
- ③ **International** and to be installed by the customer.
- ④ Roof of the car lift.
- ⑤ Height of the flooring. The standard value of X = 50mm.
- ⑥ Flooring on the roof (max. 250 kg/m²) and surrounding to be performed by the customer. The total lifting capacity of the lift is including the vehicle to be lifted and the weight of the flooring on the roof of the lift.
For example: if the max lifting capacity of the lift = 5000 kg, Car to be lifted (3000 kg) + the flooring weight on the roof of the lift (2000 kg) should not exceed 5000 kg.
- ⑦ Waterproofing on the roof and lift shaft to be performed by the customer.
- ⑧ Surrounding drainage channel with connection to sewerage system to be performed by the customer.

► Detail building construction – Hydraulic & Electric unit

The room where to place the hydraulic unit and the electric control panel will be positioned must be chosen carefully and must be easily accessible from the outside. It is recommended that this room be closed with its own door with a key.

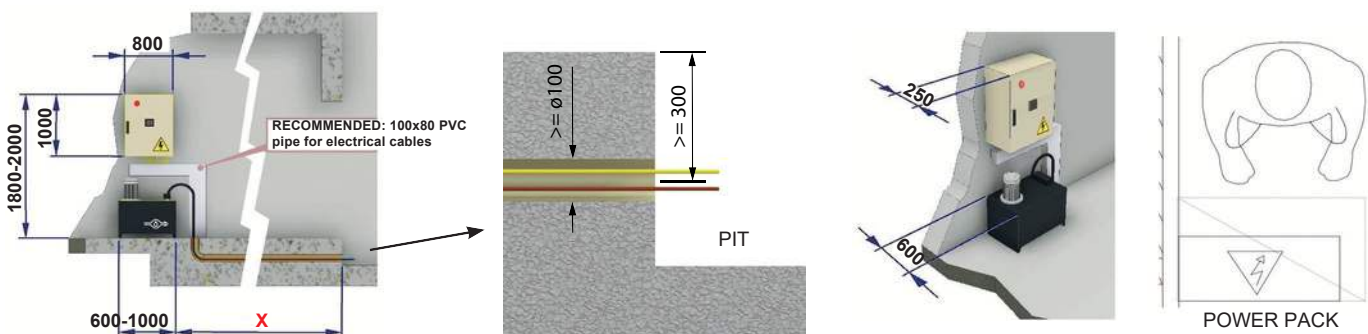

- The room chosen must have adequate ventilation to allow the electric motor to dissipate the heat produced during operation (< 50°C).
- Arrange plastic ducts as indicated for containing all the electrical cables coming from the pit compartment, push-button panels, doors etc.
- The pit must be connected to the electrical panel with 2 separate pipes with a minimum diameter of 100 mm to allow the passage of electric cables and hydraulic hoses. Avoid 90° bends in the pipes.
- When positioning the electrical panel and the hydraulic power unit, consider the measures indicated and provide sufficient space in front of it to ensure easy maintenance.

Page 1
Specification,
Variants and
Dimensions

Page 2
Lift position,
Lift with
garage door,
Approach

Page 3
Drainage
plan, Detail
building
construction

Page 4
Loadplan,
Electrical
installation

Page 5
Technical
hints

Page 6
Facilities from
customer

Page 7
Description

► **Load plan**

- The car lift are anchored into the side walls and ground. The drill hole depth on the floor is approx. 15 cm, and on the walls approx. 12 cm.
- Floor and walls below the drive-in level must be made of concrete (concrete quality min. C20/25)!
- The dimensions of the load-bearing points are approximate. If the exact dimensions are required, please consult **Car Stackers International**.

Section view

Top view

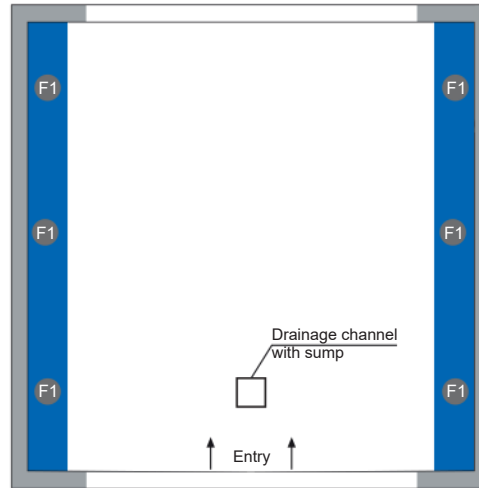
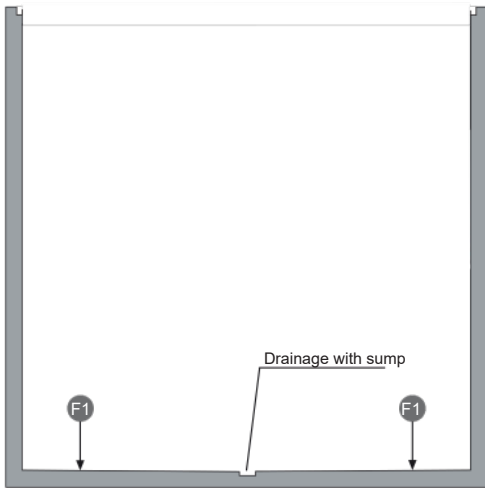

Force (kN)
F1
+70

► **Electrical installation**

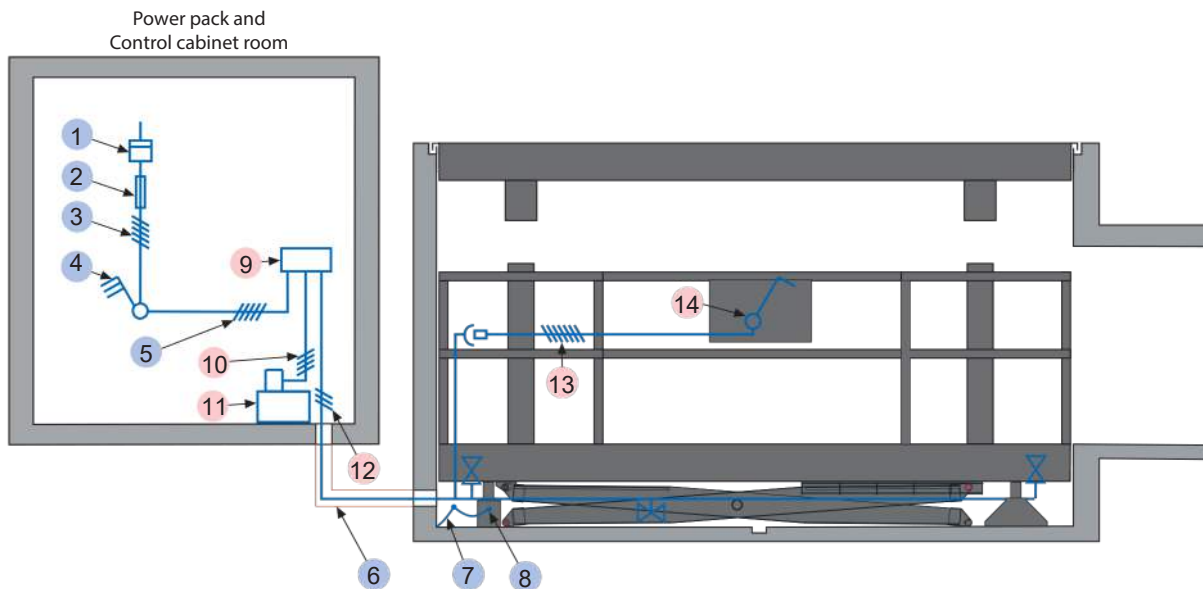

Electrical data to be performed by the customer

No.	Qty.	Description	Postion
1	1	Electricity meter	in the supply line in the supply line to
2	1	Main fuse : 3 x fuse 32 A (slow) or circuit breaker 3 x 32 A (trigger characteristic K, G or C)	main switch defined at the plan
3	1	Supply line 5 x 2.5 mm ² (3 PH + N + PE) with marked wire and protective conductor	check from main switch to unit from
4	1	Lockable main switch	power pack and control cabinet
5	1	Supply line 5 x 2,5 mm ² (3 PH + N + PE) with marked wire and protective conductor	corner of pit floor
6	2	Min. ø100 pipe	to pit floor
7	every 10 m	Foundation earth connector	
8	1	Potential equalization from foundation grounding connection system according to DIN EN 60204	

Electrical data

No.	Designation
9	Junction box unit
10	Control line 4 x 2,5 mm ² with marked wire and protective conductor
11	Hydraulic unit 5.2 kW / 11 kW, three phase current, 230/400 V, 50 Hz
12	Control line 3 x 1 mm ² (PH + N + PE)
13	Control line 4 x 1 mm ² with marked wire and protective conductor
14	Operating device

► Technical hint

Usage area

The system is suitable for outdoor installation and to lift heavy and large cars with a driver on board. The car lift is suitable for residential as well as office buildings. Feel free to contact **Car Stackers International** for consultation.

Units

Low-noise hydraulic units are installed. We also recommend separating the garage body from the residential building. The hydraulic unit and the electrical components must be housed in a cabinet (see “**Detail building construction – Hydraulic & Electric unit**”, page 3).

CE certification

The systems offered correspond to the EC Machinery Directive 2006/42/CE.

Building application documents

According to the EC Machinery Directive 2006/42/CE, the **Car Lift** systems are subject to approval. Please observe the local rules and regulations.

Available documents

- Wall recess plans
- Maintenance offer / contract
- Declaration of conformity

Environmental conditions

Ambient conditions for the areas around car lift systems:

- Temperature range -10 °C to +40 °C
- Relative humidity of 50% at a maximum outside temperature of +40 °C.

The lifting and lowering of the car lift are calculated at an ambient temperature of +10 °C and with the hydraulic system positioned immediately adjacent to the car lift. The operating time of car lift increases at lower ambient temperatures or with longer hydraulic lines.

Care & Protection

To avoid corrosion damage, please follow separate cleaning and care instructions (as per the “**Corrosion protection**” sheet) and ensure that your garage is well ventilated.

Noise protection

Standard noise protection:

As per DIN 4109-1 (Sound insulation in buildings – Part 1: Minimum requirements) - Section 9:

- Maximum noise level in living and sleeping areas 30 dB (A).

Noise created by users are not considered.

The following dimensions are required for adherence to this value:

- Noise protection package in accordance with quote/order (**Car Stackers International**).
- Noise insulation dimension of the building structure of minimum weighted sound reduction index, min. $R'w = 57$ dB (service to be provided by the customer)

Increased noise protection (special agreement):

As per DIN 4109-5 (Sound insulation in buildings - Part 5: Increased requirements) - Section 8: ■ Maximum noise pressure level in living and sleeping areas 25 dB (A). Noise created by users are not considered.

The following dimensions are required for adherence to this value:

- Noise protection package in accordance with quote/order (**Car Stackers**)
- Noise insulation dimension of the building structure of min. $R'w = 62$ dB (service to be provided by the customer)

HINT : User noises are the noises that can be influenced by individual users of our **Car Lift** systems. These are created during the accessing of the platform, slamming of vehicle doors, engine, and brake noise.

Page 1
Specification,
Variants and
Dimensions

Page 2
Lift position,
Lift with
garage door,
Approach

Page 3
Drainage
plan, Detail
building
construction

Page 4
Loadplan,
Electrical
installation

Page 5
Technical
hints

Page 6
Facilities from
customer

Page 7
Description

► **Facilities to be provided by the customer**

Safety barriers

During the car lift construction, in accordance with DIN EN ISO 13857, safety barriers are to be placed immediately in front of, adjacent to, or behind the systems where there are roadways.

Building services

Any lighting, ventilation, fire extinguishing and fire alarm systems, as well as clarification and compliance with the relevant regulatory requirements.

Ventilation

To ensure a continuous exchange of air, to reduce air humidity, prevent condensation and reduce vehicle moisture (from rain, snow, etc.), we recommend that the customer provide a ventilation system in conjunction with a specialist. This will help to minimise the risk of corrosion and resulting faults.

Lighting

The customer must observe local regulations pertaining to the illumination of parking spaces and roadways. In accordance with DIN EN 12464-1 'Light and lighting - Lighting of work places', an illumination level of min. 200 lx is recommended for the parking spaces and operating area of the system.

Drainage

A pump or drain sewerage is to be installed in the drainage sump (50 x 50 x 20 cm) inside the pit to avoid stagnant water (Component defect due to stagnant water will no longer be covered under warranty). For reasons of environmental protection, we recommend painting the pit floor, and to provide oil and petrol separators in the connections to the public sewage network.

Electrical supply to the main switch / Foundation earth connector

The customer must lay the supply cable to the master switch during assembly. Functional capability can be checked by our engineers on-site, in conjunction with the electrical engineer. If this is not possible during assembly for reasons attributable to the customer, the customer must commission an electrical engineer. The customer must earth the steel structure with a foundation earth connection (earthing distance max. 10 m) and equipotential bonding in accordance with DIN EN 60204 (see "Electrical installation", page 4)

Control panel

Empty conduits and recesses for the operating element (see "Electrical installation", page 4). Consultation with **Car Stackers** is required when using folding doors.

Control panel on plaster

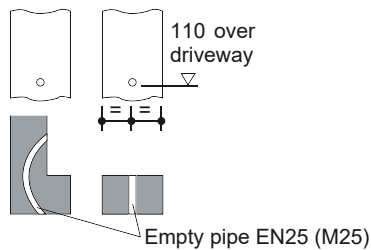

If the following are not included in the quotation, they will also have to be provided/paid for by the customer:

- Mounting of contactor and terminal box to the wall valve, complete wiring of all elements in accordance with the circuit diagram
- Costs for final technical approval by an authorized body
- Main switch
- Control line from main switch to hydraulic unit
- Railing

Page 1
Specification,
Variants and
Dimensions

Page 2
Lift position,
Lift with
garage door,
Approach

Page 3
Drainage
plan, Detail
building
construction

Page 4
Loadplan,
Electrical
installation

Page 5
Technical
hints

Page 6
Facilities from
customer

Page 7
Description

► Description - Car lift with driver on board

General description

- **The Car Lift systems** are for lifting heavy and large cars with a driver on board. The upper platform or roof may be used as a parking space under specific conditions.
- Dimensions according to the underlying pit, width and height dimensions.
- Passenger car positioning on car lift by means of positioning sensors on both sides (to be set in accordance with the operating instructions).
- Operation via a control element with Dead man's switch.
- Fixing the control element usually in front of the entrance or on the way revealing the outside.
- Operating instructions at every operating point.
- For car lifts with an entrance door, special dimensions must be respected.

Car Lift system consisting of:

- 2 Rigid bases with foundation (fixed to the floor)
- 5 Hydraulic cylinders
- 1 Lower platform
- 1 Upper platform or Roof
- 4 support pillars for the roof
- 4 scissor members
- 6 support beams for scissor members
- 4 / 8 Nylon guide rollers
- Dowels, screws, fasteners, connecting elements etc.

Platform consisting of:

- Checker plates
- Side fence
- Crossbeams
- Lateral beams
- Brackets
- Screws, nuts, etc.

Hydraulics consisting of:

- Hydraulic cylinders
- Solenoid valve
- Safety valves
- Hydraulic lines
- Hydraulic fittings
- High-pressure hoses
- Mounting material

Electrical system consisting of:

- 2 Operating elements (Emergency-stop, lock, access via RFID)
- Upto 4 safety light curtains for edge control
- Junction box unit
- Control cabinet

Hydraulic unit consisting of:

- Hydraulic oil tank
- Oil filling
- Internal gear pump
- Pump holder
- Coupling
- Three-phase motor (5.2 kW / 11 kW, 230/400 V, 50 Hz, low noise)
- Pressure gauge
- Pressure relief valve
- Hydraulic hoses (to reduce noise transmission to the hydraulic pipes)

We reserve the right to change these specifications without notice!

Car Stackers reserves the right, in the course of technical and technological progress, to use newer or different technologies, systems, processes, procedures, or standards than those originally offered and ensure that the customer does not incur any disadvantage.

Page 1
Specification,
Variants and
Dimensions

Page 2
Lift position,
Lift with
garage door,
Approach

Page 3
Drainage
plan, Detail
building
construction

Page 4
Loadplan,
Electrical
installation

Page 5
Technical
hints

Page 6
Facilities from
customer

Page 7
Description

STORE-R-5-P

Carlift

Specification

- Stroke = up to 3700 mm
- Platform length = up to 6450 mm
- Platform width = up to 3000 mm
- Lifting capacity = up to 5000 kg ¹
- Estimated speed = 6 to 8 cm/sec

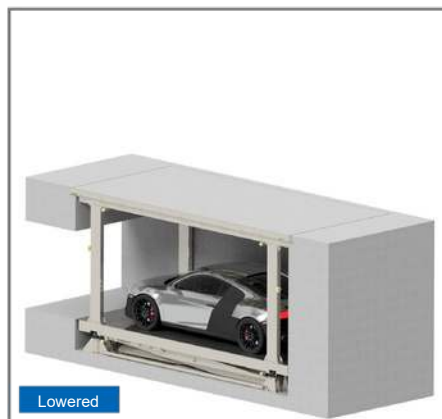
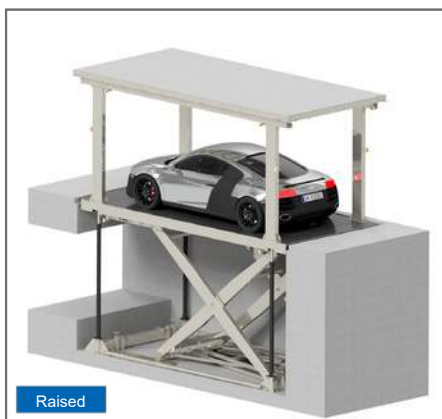

Model without driver on board

2 3

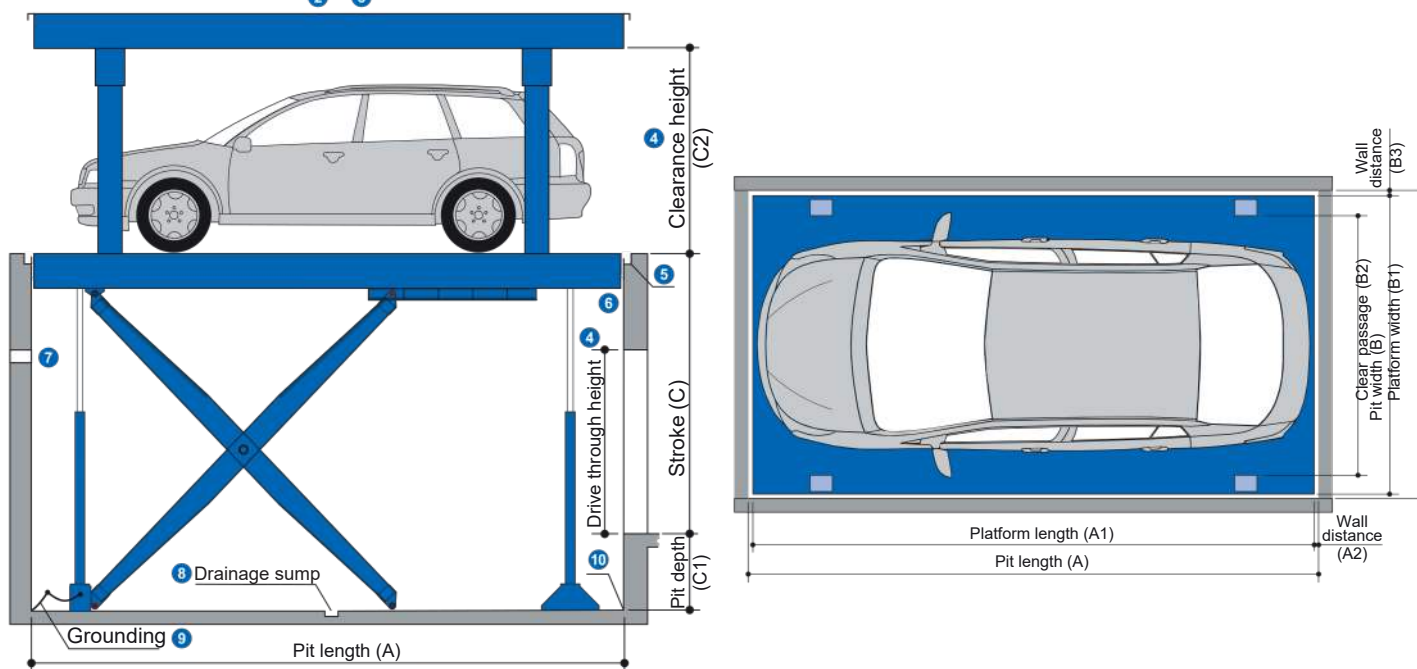

Parameter		Standard (mm)	Max (mm)
Pit length	A	5360	6500
Platform length	A1	5310	6450
Wall distance	A2	25	
Pit width	B	2500	3000
Platform width	B1	2450	2950
Clear passage	B2	2200	2700
Wall distance	B3	25	
Stroke	C	2700	3700
Pit depth	C1	570 to 620	
Clear passage	C2	1800	2200

Notes

- ¹ Lifting capacity of the lift = Car to be lifted + Flooring weight on the roof of the lift (max. 250 kg/m²).
For example: if the max lifting capacity of the lift = 5000 kg, Car to be lifted (3000 kg) + flooring weight on roof of the lift (2000 kg) should not exceed 5000 kg. For countries with snowfall, the excessive snow on the lift is to be cleared before operating.
- ² During the lowered position of the lift, the roof of the lift can be considered as a parking space under specific conditions. The vehicle parked on the roof
- ³ should be removed before operating the lift.
Must be at least as high as the greatest car height + 5 cm.
- ⁴ Surrounding drainage system with connection to sewerage system to be performed by the customer (see "Drainage plan", page 3).
- ⁵ To comply with the minimum finished dimensions of the lift shaft, tolerances for space requirements +³/₀ according to VOB, Part C (DIN 18330 and 18331)
- ⁶ and DIN 18202 must also be considered. Dimensions are in cm.
Ventilation inside the lift shaft has to be provided by the customer and must conform to **AS 5124**.
- ⁷ Grounding of the system to be connected to the central grounding on-site (to be provided by the customer).
- ⁸ Drainage sump : 10 x 2 cm with 50 x 50 x 50 cm drainage pit, install a sump pump (refer to manufacturer's dimensions).
- ⁹ At the transition section between the pit floor and walls, no hollow mouldings/coves are possible. If hollow mouldings/coves are required, the systems must
- ¹⁰ be designed smaller or the pits accordingly wider.

Page 1
Specification, Variants and Dimensions

Page 2
Lift position, Lift with garage door, Approach

Page 3
Drainage plan, Detail building construction

Page 4
Loadplan, Electrical installation

Page 5
Technical hints

Page 6
Facilities from customer

Page 7
Description

► Lift position

System raised

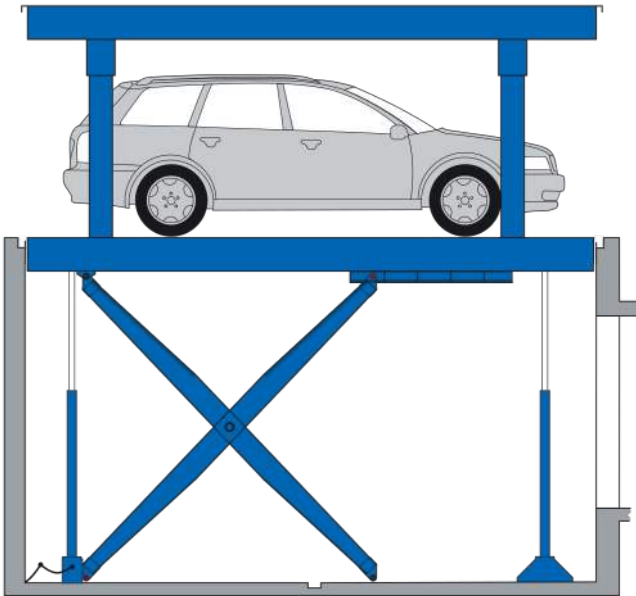

System lowered

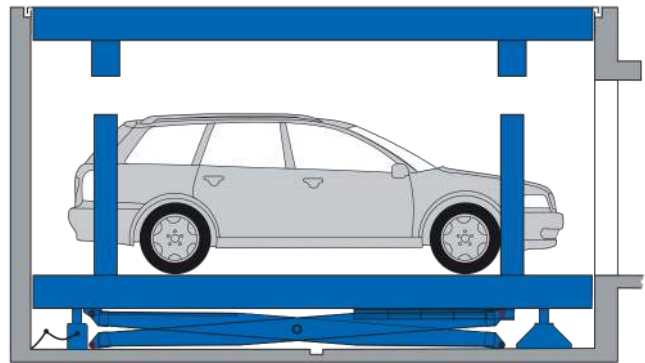

Page 1
Specification,
Variants and
Dimensions

Page 2
Lift position,
Lift with
garage door,
Approach

Page 3
Drainage
plan, Detail
building
construction

Page 4
Loadplan,
Electrical
installation

Page 5
Technical
hints

► Lift with garage door

Sectional garage door

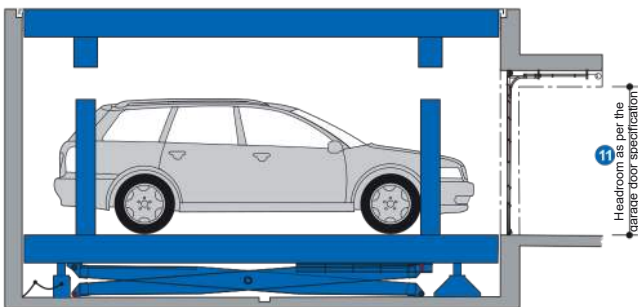

Roll-up garage door

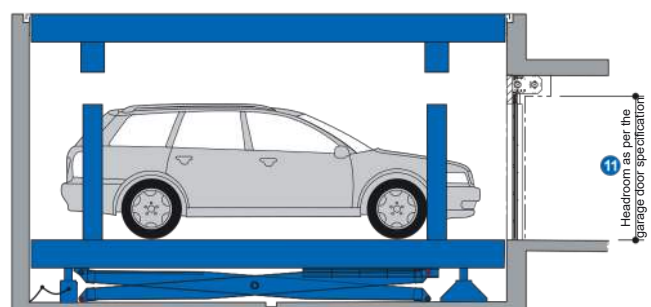

11 Dimensions for all doors must be coordinated with the door supplier. Coordination between the door manufacturer and **Car Stackers International** is necessary.

Page 6
Facilities from
customer

Page 7
Description

► Approach

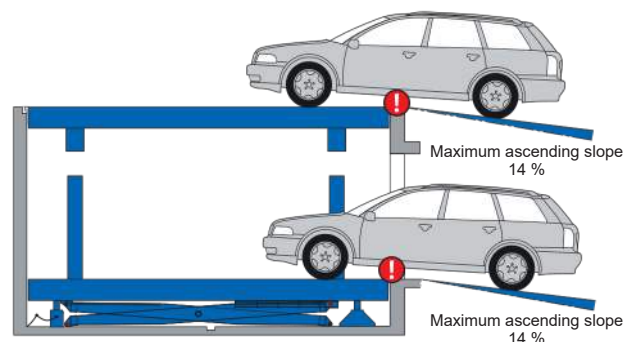
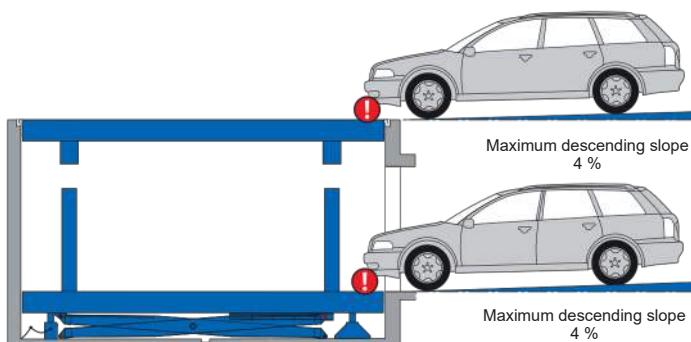

The illustrated maximum approach angles must not be exceeded. Incorrect approach angles will cause serious maneuvering and positioning problems on the parking system for which the company **Car Stackers** accepts no responsibility.

► Drainage plan

Overview of the pit

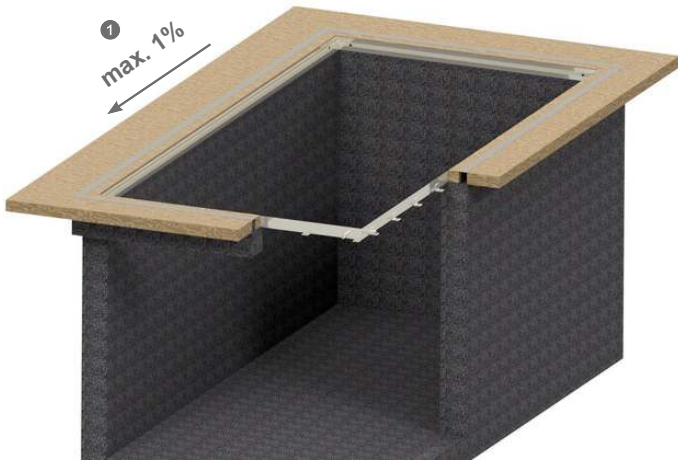

Section view of drainage channel

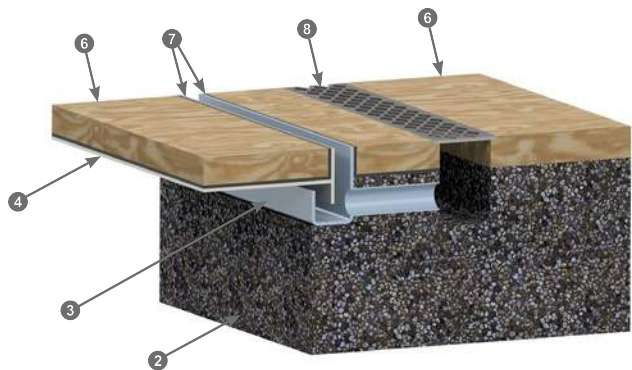

Section view of drainage channel

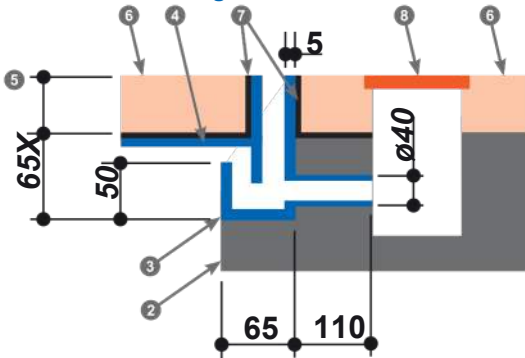

Notes :

- 1 The slope of the drainage channel towards the entrance side. Inner wall of
- 2 the lift shaft. Drainage channel will be provided by **Car Stackers** and to be installed by the customer.
- 3 Roof of the car lift.
- 4 Height of the flooring. The standard value of X = 50mm.
- 5 Flooring on the roof (max. 250 kg/m²) and surrounding to be performed by the customer. The total lifting capacity of the lift is including the vehicle to be lifted and the weight of the flooring on the roof of the lift.
For example: if the max lifting capacity of the lift = 5000 kg, Car to be lifted (3000 kg) + the flooring weight on the roof of the lift (2000 kg) should not exceed 5000 kg.
- 6 Waterproofing on the roof and lift shaft to be performed by the customer.
- 7 Surrounding drainage channel with connection to sewerage system to be performed by the customer.
- 8

► Detail building construction – Hydraulic & Electric unit

The room where to place the hydraulic unit and the electric control panel will be positioned must be chosen carefully and must be easily accessible from the outside. It is recommended that this room be closed with its own door with a key.

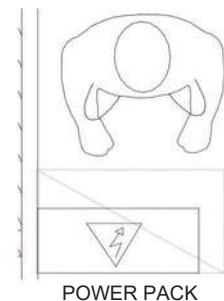
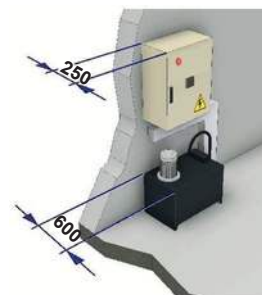
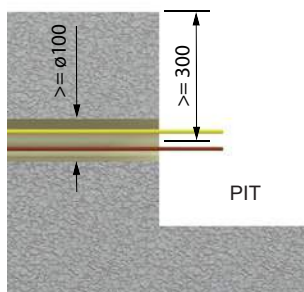
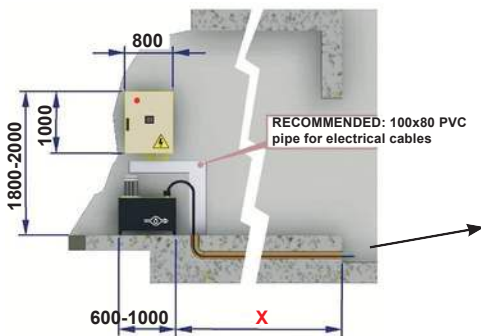

- The room chosen must have adequate ventilation to allow the electric motor to dissipate the heat produced during operation (< 50°C).
- Arrange plastic ducts as indicated for containing all the electrical cables coming from the pit compartment, push-button panels, doors etc.
- The pit must be connected to the electrical panel with 2 separate pipes with a minimum diameter of 100 mm to allow the passage of electric cables and hydraulic hoses. Avoid 90° bends in the pipes.
- When positioning the electrical panel and the hydraulic power unit, consider the measures indicated and provide sufficient space in front of it to ensure easy maintenance.

Page 1
Specification,
Variants and
Dimensions

Page 2
Lift position,
Lift with
garage door,
Approach

Page 3
Drainage
plan, Detail
building
construction

Page 4
Loadplan,
Electrical
installation

Page 5
Technical
hints

Page 6
Facilitiesfrom
customer

Page 7
Description

► **Load plan**

- The car lift are anchored into the side walls and ground. The drill hole depth on the floor is approx. 15 cm, and on the walls approx. 12 cm.
- Floor and walls below the drive-in level must be made of concrete (concrete quality min. C20/25)!
- The dimensions of the load-bearing points are approximate. If the exact dimensions are required, please consult **Car Stackers International**

Section view

Top view

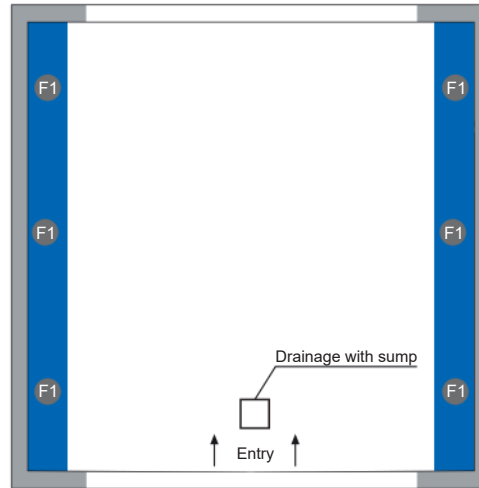
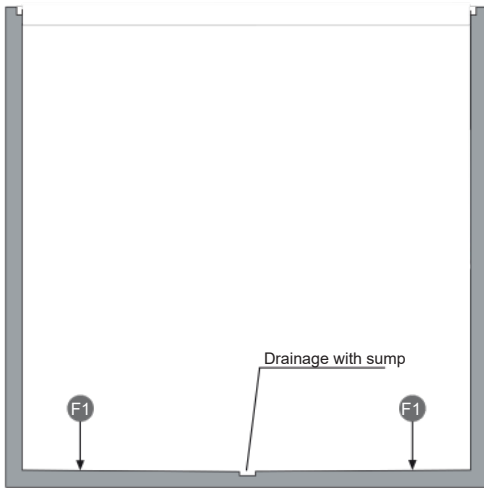

Force (kN)
F1
+70

► **Electrical installation**

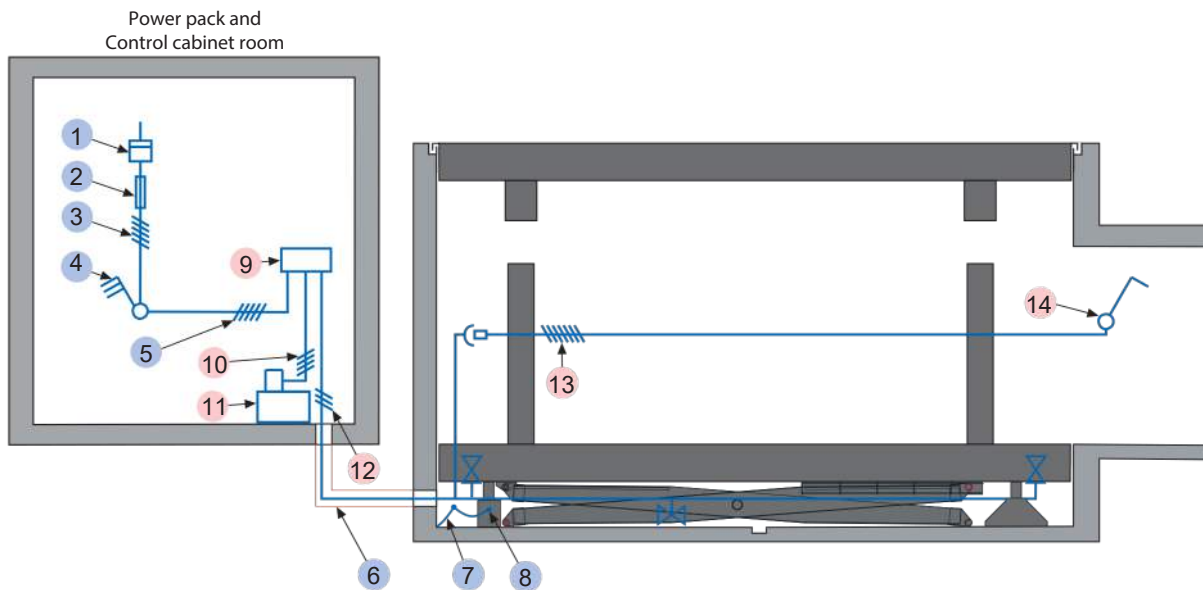

Electrical data to be performed by the customer

No.	Qty.	Description	Position
1	1	Electricity meter	in the supply line in the supply line to
2	1	Main fuse : 3 x fuse 32 A (slow) or circuit breaker 3 x 32 A (trigger characteristic K, G or C)	main switch defined at the plan
3	1	Supply line 5 x 2.5 mm ² (3 PH + N + PE) with marked wire and protective conductor	check from main switch to unit from
4	1	Lockable main switch	power pack and control cabinet
5	1	Supply line 5 x 2,5 mm ² (3 PH + N + PE) with marked wire and protective conductor	corner of pit floor
6	2	Min. ø100 pipes	to pit floor
7	every 10 m	Foundation earth connector	
8	1	Potential equalization from foundation grounding connection system according to DIN EN 60204	

Electrical data

No.	Designation
9	Junction box unit
10	Control line 4 x 2,5 mm ² with marked wire and protective conductor
11	Hydraulic unit 5.2 kW / 11 kW, three phase current, 230/400 V, 50 Hz
12	Control line 3 x 1 mm ² (PH + N + PE)
13	Control line 4 x 1 mm ² with marked wire and protective conductor
14	Operating device

► Technical hint

Usage area

The system is suitable for indoor installation and to lift heavy and large cars without a driver on board. The car lift is suitable for residential as well as office buildings.

Units

Low-noise hydraulic units are installed. We also recommend separating the garage body from the residential building. The hydraulic unit and the electrical components must be housed in a cabinet (see “**Detail building construction – Hydraulic & Electric unit**”, page 3).

CE certification

The systems offered correspond to the EC Machinery Directive 2006/42/CE.

Building application documents

According to the EC Machinery Directive 2006/42/CE, the Car Lift systems are subject to approval. Please observe the local rules and regulations.

Available documents

- Wall recess plans
- Maintenance offer / contract
- Declaration of conformity

Environmental conditions

Ambient conditions for the areas around car lift systems:

- Temperature range -10 °C to +40 °C
- Relative humidity of 50% at a maximum outside temperature of +40 °C.

The lifting and lowering of the car lift are calculated at an ambient temperature of +10 °C and with the hydraulic system positioned immediately adjacent to the car lift. The operating time of car lift increases at lower ambient temperatures or with longer hydraulic lines.

Care & Protection

To avoid corrosion damage, please follow separate cleaning and care instructions (as per the “**Corrosion protection**” sheet) and ensure that your garage is well ventilated.

Noise protection

Standard noise protection:

As per DIN 4109-1 (Sound insulation in buildings – Part 1: Minimum requirements) - Section 9: ■ Maximum noise level in living and sleeping areas 30 dB (A). Noise created by users are not considered.

The following dimensions are required for adherence to this value:

- Noise protection package in accordance with quote/order (**Car Stackers**).
- Noise insulation dimension of the building structure of minimum weighted sound reduction index, min. $R'w = 57$ dB (service to be provided by the customer)

Increased noise protection (special agreement):

As per DIN 4109-5 (Sound insulation in buildings - Part 5: Increased requirements) - Section 8: ■ Maximum noise pressure level in living and sleeping areas 25 dB (A). Noise created by users are not considered.

The following dimensions are required for adherence to this value:

- Noise protection package in accordance with quote/order (**Car Stackers**).
- Noise insulation dimension of the building structure of min. $R'w = 62$ dB (service to be provided by the customer)

HINT : User noises are the noises that can be influenced by individual users of our **Car Lift** systems. These are created during the accessing of the platform, slamming of vehicle doors, engine, and brake noise.

Page 1
Specification,
Variants and
Dimensions

Page 2
Lift position,
Lift with
garage door,
Approach

Page 3
Drainage
plan, Detail
building
construction

Page 4
Loadplan,
Electrical
installation

Page 5
Technical
hints

Page 6
Facilities from
customer

Page 7
Description

► **Facilities to be provided by the customer**

Safety barriers

During the car lift construction, in accordance with DIN EN ISO 13857, safety barriers are to be placed immediately in front of, adjacent to, or behind the systems where there are roadways.

Building services

Any lighting, ventilation, fire extinguishing and fire alarm systems, as well as clarification and compliance with the relevant regulatory requirements.

Ventilation

To ensure a continuous exchange of air, to reduce air humidity, prevent condensation and reduce vehicle moisture (from rain, snow, etc.), we recommend that the customer provide a ventilation system in conjunction with a specialist. This will help to minimise the risk of corrosion and resulting faults.

Lighting

The customer must observe local regulations pertaining to the illumination of parking spaces and roadways. In accordance with DIN EN 12464-1 'Light and lighting - Lighting of work places', an illumination level of min. 200 lx is recommended for the parking spaces and operating area of the system.

Drainage

A pump or drain sewerage is to be installed in the drainage sump (50 x 50 x 20 cm) inside the pit to avoid stagnant water (Component defect due to stagnant water will no longer be covered under warranty). For reasons of environmental protection, we recommend painting the pit floor, and to provide oil and petrol separators in the connections to the public sewage network.

Electrical supply to the main switch / Foundation earth connector

The customer must lay the supply cable to the master switch during assembly. Functional capability can be checked by our engineers on-site, in conjunction with the electrical engineer. If this is not possible during assembly for reasons attributable to the customer, the customer must commission an electrical engineer. The customer must earth the steel structure with a foundation earth connection (earthing distance max. 10 m) and equipotential bonding in accordance with DIN EN 60204 (see "Electrical installation", page 4)

is

Control panel on plaster

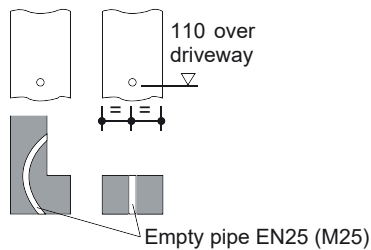

If the following are not included in the quotation, they will also have to be provided/paid for by the customer:

- Mounting of contactor and terminal box to the wall valve, complete wiring of all elements in accordance with the circuit diagram
- Costs for final technical approval by an authorized body
- Main switch
- Control line from main switch to hydraulic unit
- Railing

► Description - Car lift without driver on board

General description

- The car lifts are for lifting heavy and large cars without a driver on board. The upper platform or roof may be used as a parking space under specific conditions.
- Dimensions according to the underlying pit, width and height dimensions.
- Passenger car positioning on car lift by means of positioning sensors on both sides (to be set in accordance with the operating instructions).
- Operation via a control element with Dead man's switch.
- Fixing the control element usually in front of the entrance or on the way revealing the outside.
- Operating instructions at every operating point.
- For car lifts with an entrance door, special dimensions must be respected.

The Car Lift system consisting of:

- 2 Rigid bases with foundation (fixed to the floor)
- 5 Hydraulic cylinders
- 1 Lower platform
- 1 Upper platform or Roof
- 4 Support pillars for the roof
- 4 scissor members
- 6 support beams for scissor members
- 4 / 8 Nylon guide rollers
- Dowels, screws, fasteners, connecting elements etc.

Platform consisting of:

- Checker plates
- Crossbeams
- Lateral beams
- Brackets
- Screws, nuts, etc.

Hydraulics consisting of:

- Hydraulic cylinders
- Solenoid valve
- Safety valves
- Hydraulic lines
- Hydraulic fittings
- High-pressure hoses
- Mounting material

Electrical system consisting of:

- 2 Operating elements (Emergency-stop, lock, access via RFID)
- Junction box unit
- Control cabinet

Hydraulic unit consisting of:

- Hydraulic oil tank
- Oil filling
- Internal gear pump
- Pump holder
- Coupling
- Three-phase motor (5.2 kW / 11 kW, 230/400 V, 50 Hz, low noise)
- Pressure gauge
- Pressure relief valve
- Hydraulic hoses (to reduce noise transmission to the hydraulic pipes)

We reserve the right to change these specifications without notice!

Car Stackers reserves the right, in the course of technical and technological progress, to use newer or different technologies, systems, processes, procedures, or standards than those originally offered and ensure that the customer does not incur any disadvantage.

Page 1
Specification,
Variants and
Dimensions

Page 2
Lift position,
Lift with
garage door,
Approach

Page 3
Drainage
plan, Detail
building
construction

Page 4
Loadplan,
Electrical
installation

Page 5
Technical
hints

Page 6
Facilities from
customer

Page 7
Description