

Nussbaum

BY CAR STACKERS INTERNATIONAL

UNIPARKER N5403

THE SEMI-AUTOMATIC PARKING SYSTEM WITH 1 ENTRANCE LEVEL AND 2 LEVELS IN THE PIT



SHORT DESCRIPTION

- INDEPENDENT PARKING ON 3 LEVELS, WITH 2 LEVELS IN THE PIT
- LOWER LEVEL PROVIDED WITH LIFTING PLATFORMS, MIDDLE LEVEL WITH LIFTING/SLIDING PLATFORMS, ENTRANCE LEVEL WITH SLIDING PLATFORMS. WITH 2 EMPTY SPACES
- MODULAR CONSTRUCTION: DEPENDING ON THE CONDITIONS ON SITE, IT CAN BE POSSIBLE TO ADD SEGMENTS AT WILL
- LOAD PER PARKING SPACE: STANDARD 2.000 KG
OPTIONAL UP TO 2.300 KG OR 2.600 KG

APPLICATION

- FOR INTERIORS AND EXTERIORS
- ONE AND MULTI-FAMILY DWELLINGS
- HOTELS
- OFFICE BUILDINGS
- CONDOMINIUMS
- COMMERCIALS
- CAR DEALERS
- FOR PERMANENT USERS ONLY

HEIGHT MEASUREMENTS



Modular construction extensible at will

The system is provided with single columns at the back, on the front with common columns.

Platforms can be driven horizontally.

For a constant, trained group of users.

Drainage channel 10x10 with collecting pit 50x50x20. Inclination to the channel can be chosen at will from 2%.

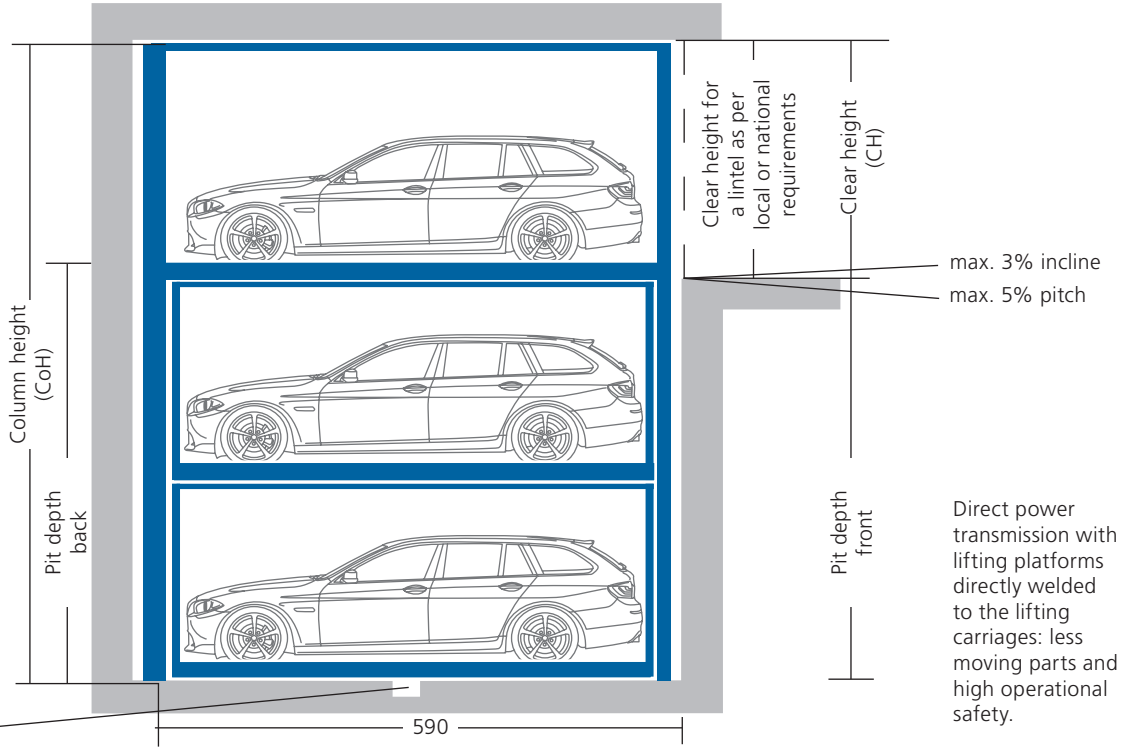

NOTE

The total height of the car including roof rail and antenna fixture must not exceed the maximum car height mentioned in the table below. Standard cars do not feature sport equipment (e.g. spoiler, etc.)

System length 590 cm, for 500 cm long cars. Further dimensions upon request.

Concrete: min. 18, C25, floor evenness acc. to DIN 18202 tab. 3, line 3.

Load per parking space: max. 2.000 kg, wheel load: max. 500kg. Optionally up to 2.300 kg or max. 2.600kg, wheel load max. 650kg.

PIT DEPTH FRONT/BACK	COLUMN HEIGHT (CoH)	CLEAR HEIGHT (CH)	CAR-HEIGHT BELOW	CAR-HEIGHT MIDDLE	CAR-HEIGHT ABOVE*
370	575	from 210	153	153	185
390	605	from 220	163	163	195
410	635	from 230	173	173	205
430	665	from 240	183	183	215
450	695	from 250	193	193	225

* The car-height above depends on the clear height: in case you have more clear height you can park respectively higher cars.

All measurements are in cm.

VEHICLE DATA: STANDARD CAR

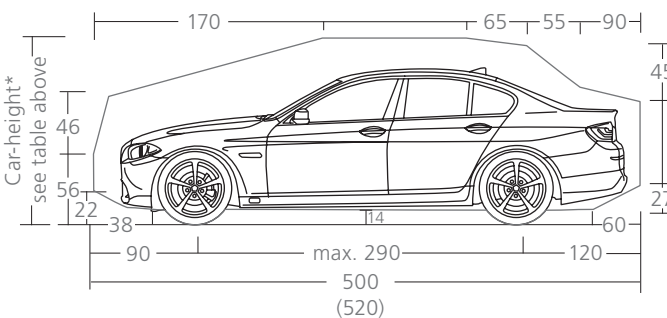

VEHICLE DATA: STANDARD ESTATE CAR

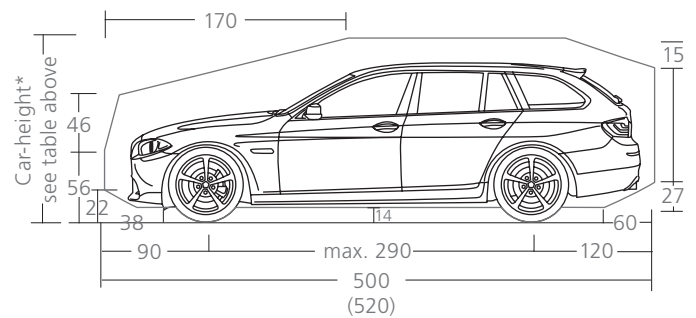

WIDTH DIMENSIONS AND EXAMPLES

EXAMPLE WITH 3 SEGMENTS FOR 7 PARKING SPACES

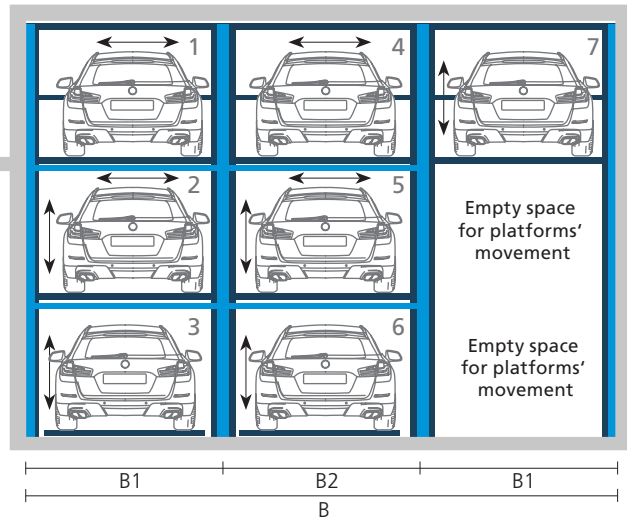

Example 1 - basis position

The picture shows the basis position: on the entrance level, for safety reasons, there is one lifting platform (7). Now it is possible to drive out cars 1, 4 as well as 7. In the basis positions the empty spaces are positioned on the right side, although optionally they can be placed on the left side instead.

THE UNIPARKER N5403 AT A GLANCE

On the entrance level there are sliding platforms with one empty space. On the lowest level, the system is provided with lifting/sliding platforms and the middle level is provided with lifting/sliding platforms. In the middle level there is a further empty space. The platforms in the middle level are alternatively coupled on the upper lifting platform (by C- profiles) or on the lower sliding platform (by bolts).

The smallest unit is composed by 2 Segments for 4 cars. The system can be extended at will by adding segments. Anyway we suggest to combine no more than 10 segments for 28 cars with a common power unit, to keep a quick access time.

CLEAR PLATFORM WIDTH			FRAME		TOTAL MEASUREMENTS FOR x SEGMENTS									
SLIDING*	SLIDING/LIFTING*	LIFTING	OUTER (B1)	INNER (B2)	2	3	4	5	6	7	8	9	10	
225	225	230	270	255	540	795	1050	1305	1560	1815	2070	2325	2580	
230	230	235	275	260	550	810	1070	1330	1590	1850	2110	2370	2630	
240	240	245	285	270	570	840	1110	1380	1650	1920	2190	2460	2730	
250	250	255	295	280	590	870	1150	1430	1710	1990	2270	2550	2830	

* The clear entrance width is 10 cm wider.

The power unit is installed at the back wall between 2 system columns, otherwise out of the system. Power unit's measurements: (LxWxH) 45 x 22 x 60 cm.

Mind the measurements of the switch cabinet (positioned outside the system) during planning! Space needed: 100 x 100 x 100 cm, including cabinet doors' opening.

NOTE

All dimensions in cm. All dimensions are minimum dimensions. Advice for planning and tendering: Generally masonry and concrete works are to be conducted according to the German norm VOB/C (DIN 18330 and DIN 18331). The mentioned norm points the tolerances that are to be fulfilled according to DIN 18202. In this norm the maximum exceedance and shortfall of the nominal size are defined. The nominal size should be planned in order to meet the minimum dimensions necessary for the parking system.

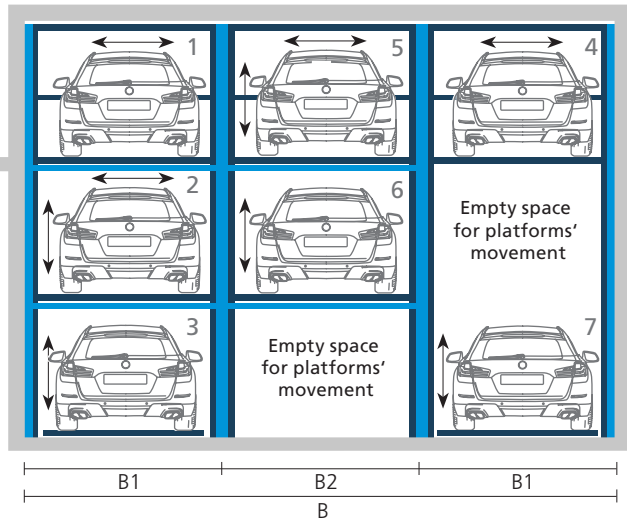

Example 2

In the picture above the lifting platform 7 has been lowered and the sliding platform 4 has been slid towards the empty space. Afterwards, the lifting platform 6 has been lifted together with the lifting/sliding platform 5. Now it is possible to drive out the cars on the sliding platforms 1 and 4, and on the lifting/sliding platform 5.

ELECTRICAL INSTALLATION AND FOUNDATION LOADS

Please observe during planning!

Services covered by the NUSSBAUM Company

POS.	QTY.	DESCRIPTION
1	1x	Hydraulic power unit with three-phase motor 400V, 50Hz, 2x 3,0kW
2	1x	Bus cable 1x 2x 0,22 to the switch cabinet
	1x	Control line 1x 12G1 to the switch cabinet
3	1x	Control unit with key switch + emergency-off
4	1x	Switch cabinet
5	1x	Segment box (for 2 segments)
6	4x	Valve (for each segment)
7	1x	Hydraulic valve (for each segment)
8	1x	Electrical motor for sliding, with cable
9	1x	Line 5x 4,0mm ² (3 PH+N+PE) with marked leads + protective earth conductor

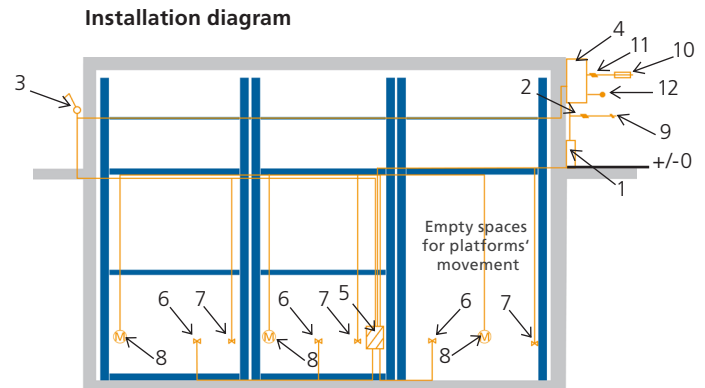

Positions 1 to 9 are included in the scope of delivery of the NUSSBAUM company, unless otherwise agreed in the offer or in the contract.

Services to be provided by the customer

POS.	QTY.	DESCRIPTION	POSITION	FREQUENCY
10	1x	Blade fuse or circuit breaker 3x 25A, slow acc. to DIN VDE 0100 part 430	in the supply line	1x power unit
11	1x	Supply line 5x 2,5mm ² (3 PH + N + PE) with marked leads + protective earth conductor	to the switch cabinet	1x power unit
12	1x	Equipotential bonding according to DIN EN 60204 from the connector of the foundation earth electrodes to the system		1x system
13	1x	Empty pipe DN 40 with taut wire to the power unit and control element	Project based	1x power unit

FOUNDATION LOADS AND CONSTRUCTION

Description

Foundation and pit walls must be planned so that they can absorb the loads of the parking system according to the schematic diagram shown on the right.

If necessary, in case of heightened foundation requirements, the chemical anchors must be provided by the client (deliverable by Nussbaum as option as well). The borehole for the footplates of the parking system must be 18 cm deep.

Ground view

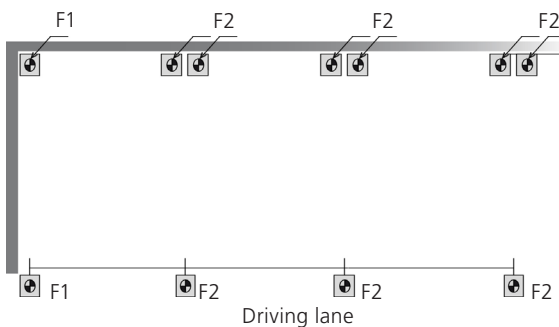

Side view

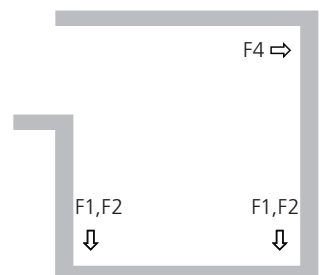

Load details

Foundation, walls and ceilings shall be realized by the customer and completed prior to assembly start and must be true to size, clean and dry. Floor and walls shall be made of armoured concrete. Concrete quality shall be at least: C25/30.

LOAD PER PARKING SPACE	VERTICAL LOADS		HORIZONTAL LOADS
	F1 (START AND END COLUMNS)	F2 (MIDDLE COLUMNS)	F4
2000 Kg	16 kN	32 kN	10 kN
2300 Kg	18 kN	36 kN	12 kN
2600 Kg	20 kN	40 kN	14 kN

METAL SLIDING GATES

Manual metal sliding gates included in the scope of delivery - Electrical gates as option

NOTE

The sliding gates need to be fastened to the available building structure otherwise additional expenses may occur.



Metal gates are included in the scope of delivery of your semi-automatic system. Optionally you can also choose other types of gate coverings.

For maximum comfort when driving in and out of the system you can even choose electrical gates, which can be opened and closed by remote control. This way you can comfortably sit in your car while parking.

The right solution for every situation. Contact us for all the optional solutions and gate coverings.

PLACEMENT OF THE OPTIONAL SLIDING GATES

There are three possibilities to install the optional sliding gates:

Layout A:

Sliding gates between the building pillars. The pillars (by client) must be positioned at least each 2 system segments.

Layout B:

Sliding gates behind the building pillars. (However, behind the gates the necessary system length of 545 cm must still be available).

Layout C:

Sliding gates in front of the building pillars.

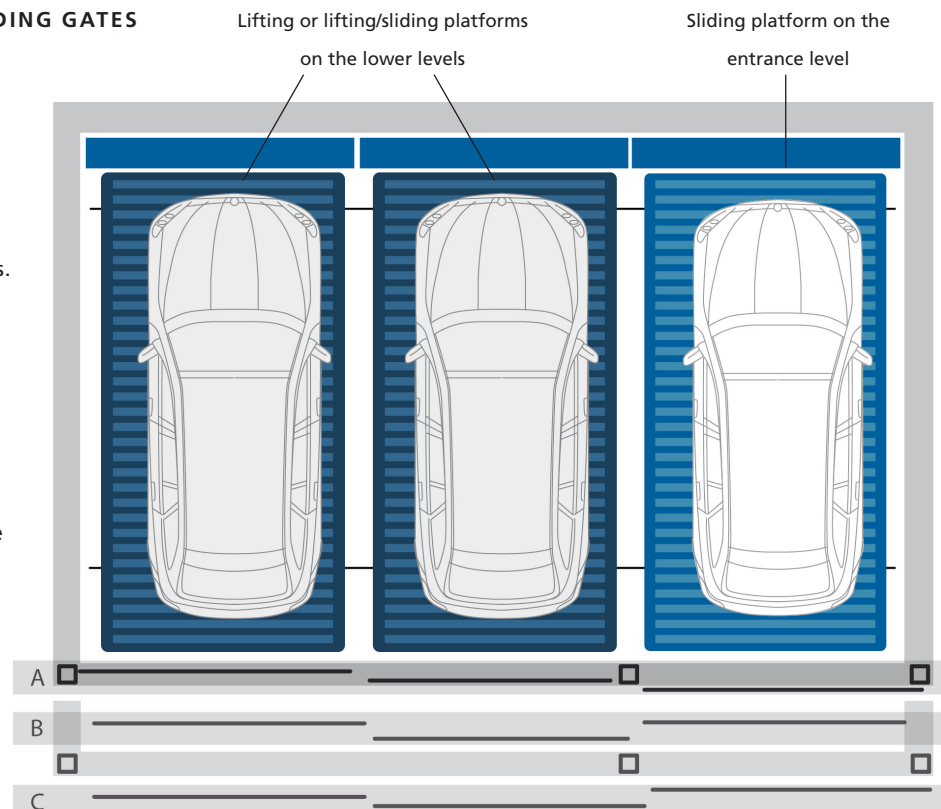

STANDARD FEATURES

Included in the scope of delivery

COMPONENT PARTS

The system is provided with electrically driven sliding platforms on the entrance level. Lifting/sliding platforms on the middle level and 2 empty spaces. Hydraulic lifting platforms on the lower level. Hydraulic motion elements and electrical steering. With gates.

DRIVING SHEETS



Platforms with side carriers and driving sheets made of trapezoidal sheet.

SYSTEM'S MEASUREMENTS

Designed for:

Parking space length: 500 cm

Parking space width: 230 cm

Parking space height: from 150 cm

Load per parking space up to 2.000 kg.

CONTROL ELEMENT



Operation by touch screen with key switch and emergency-off. With brief operating instructions fastened on the wall and cabling to the power unit.

HYDRAULIC POWER UNIT

Power unit „Silencio“



With hydraulic piping and cabling to the system. (The under oil unit is not noisy thanks to the motor-pumps-combination that absorbs sound and insulates form noise).

To shorten access time, we suggest to use one power unit for max. 10 segments.

Measurements in cm (LxWxH):

Power unit: 45 x 22 x 60 cm.

Switch cabinet: 100 x 100 x 100 cm (place for the cabinet doors included).

Positioning of the power unit:

Depending on the local conditions - preferably directly close to the back system columns or cylinders on the back.

CORROSION PROTECTION

C3-Line

For Regions with average snowfall and humidity levels (the standard in Germany).

C2-Line

Recommended only for regions with small or no snowfall and low humidity levels.

NOTE

We suggest periodical maintenance, care and cleaning. Take advantage of NUSSBAUM maintenance agreements.

ELECTRICAL INSTALLATION

For a list of services and interfaces please see the respective table in this brochure.

Two redundant wire actuated encoders.

DOCUMENTATION

Brief operating instructions (fastened to the control unit), documentation (test book and operating instructions).

SAFETY DEVICES

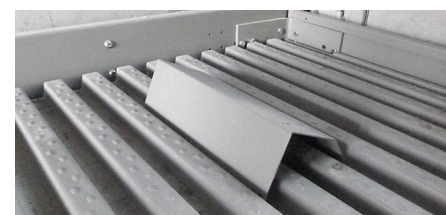

- Wedge to help position the vehicle.
- Hydraulic seated valve installed at the cylinders and hydraulic power unit as non-return device, in case of a loss of pressure.
- Fastening of the parking system and hydraulic power unit with stud-bolts, electrical cabling fastened with impact dowels.
- Safety fences on the sides against shear and crushing points, as long as the side walls are missing and they are offered by us as extra position.
- Integrated mechanical safety loop at the sliding platforms, which protects the upper lifting platforms from lowering.
- Several software-driven sensors to control the horizontal and vertical movements of the platforms.

OPTIONS AND EXTRA EQUIPMENT

Available upon request - here are illustrated only some examples...

MEASUREMENTS OF THE SYSTEM

Designed for:

Parking space length: from 510 to 530cm

Parking space width: from 235 to 270cm

Parking space height: from 153 to 225 cm

Load per parking space up to 2.600 kg.

Fastening of the parking system with chemical anchors in case of heightened foundation requirements.

ALUMINIUM: PREMIUM-COVERING



Upper platforms with aluminium-bulb plate driving sheets. (Photo: N5102)

MORE WALKING COMFORT: CATWALKS

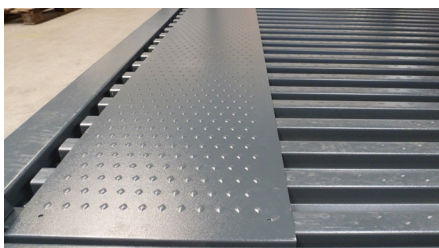

Catwalk on trapez. sheet for more walking comfort

Positioning on the left side. 1,5 mm zined sheets, embossed surface. The catwalk will be screwed to the driving sheet.

CORROSION PROTECTION

C3-Line or C4-Line

Depending on the region, for higher corrosion protection.

EXTRA SOUND INSULATION

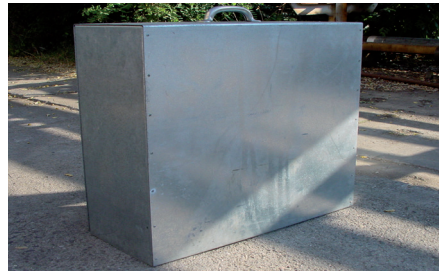

Sound insulation hood for the power unit

Airborne noise package - hood

For the power unit to reduce the airborne noise at the installation site.

Structure/borne noise package

Measures to reduce the sound propagation from the parking system to the building.

Note

In order to comply with the norm DIN 4109/A1 Table 4 „requirements for the allowed noise level in areas in need of protection from noises coming from the technical equipment“, the perimetral parts of the garage building shall be built with a sound reduction index R_w' of at least 57 dB.

HYDRAULICS

HVLP 32-330 oil for extreme temperature variations.

Heated hydraulic power unit.

SLIDING GATES

Other gate coverings instead of wire mesh are available optionally.

NOTE

We suggest periodical maintenance, care and cleaning. Take advantage of NUSSBAUM maintenance agreements.

ELECTRICAL SLIDING GATES

Electrical sliding gates can be delivered as option. Operation by remote control.

REMOTE CONTROL



The remote control delivered as option in combination with the optional electrical gates. Available in three configurations: with 1, 2 or 3 buttons:

1. (above): request a parking space (radio).
2. (right): close parking system gate (infrared).
3. (below): open/close external barrier or garage gate (radio).

MODEM FOR TELESERVICE

With our CAN-BUS control we can conduct remote service and maintenance via telephone. Delivery incl. modem. Within a few minutes our technicians can connect to the system and analyse the cause of the failure and fix the problem, often without the need of personnel on site.

By client: Modem DSL, DSL connection with fixed IP address and at least 1 MBit/s upstream.

SECOND CONTROL UNIT

Useful when building pillars impede the sight of the whole system from the control element.

SERVICES TO BE PROVIDED BY THE CUSTOMER AND PLANNING INDICATIONS

During the planning phase please observe and comply with the following notes!

SERVICES TO BE PROVIDED BY THE CUSTOMER

Safety fences

Safety fences acc. to DIN EN ISO 13857 must be provided by the customer.

Parking spaces' numeration

For the allocation of the parking spaces we suggest our customers to numerate the parking spaces.

Noise abatement measures

The compliance with these measures must be carried out by the customer acc. to norm DIN 4109: „Sound insulation in building construction“.

Electrical installation

Prior to starting the assembly the customer must provide a lockable main control switch out of the system/pit close to the power unit. Electrical services to be provided by the customer acc. to this brochure's specification.

Fire protection

The customer must agree upon the fire protection requirements and the required measures with the local fire department and realise them.

Lighting

To be carried out by the customer acc. to DIN 67528: „Lighting for parking areas and indoor car parks“.

Foundation

To be carried out by the customer acc. to the specifications in this brochure.

Control unit

The customer must make sure that a plain surface of (L x W) 50 cm x 20 cm for the installation of the control unit is directly close to the power unit and out of the platforms' moving area.

Drainage

Drainage channel 10 cm x 10 cm with collecting pit 50 cm x 50 cm x 20 cm acc. to this brochure's spec to be carried out by the customer.

Installation requirements

The compliance with installation requirements acc. to quotation.

Wall openings

In case of partition walls the customer must realise a 10 cm x 10 cm wall opening for hosting hydraulic and electrical cables.

Building permit

The customer must apply for and get the required permits in order to allow the installation of the parking system.

PLANNING INDICATIONS

Parking space width and driving lanes

While planning the parking space and driving lane dimensions please observe and comply with the local/national prescriptions for the Garages' construction. For more parking comfort we suggest you to plan parking spaces of at least 250 cm width.

Group of users

Our parking systems are conceived for a permanent and instructed group of users.

Maintenance and care

We suggest a timely conclusion of a maintenance agreement.

We suggest also to perform maintenance, care and cleaning at regular time intervals.

EG-Machinery directive

Our parking systems comply with the EG-Machinery directive and are CE certified according to the norm DIN EN 14010.

Ramps' inclination

Ramps leading to garages shall not have more than 15% inclination.

Modifications

The company Nussbaum Parking GmbH reserves the right to make dimensional, design and technical modifications.