

Nussbaum

BY CAR STACKERS INTERNATIONAL

UNIPARKER N5303

THE SEMI-AUTOMATIC PARKING SYSTEM WITH PIT AND WITHOUT COLUMNS AT THE ENTRY



SHORT DESCRIPTION

- INDEPENDENT PARKING ON 3 LEVELS, WITH PIT
- UPPER AND LOWERLEVEL WITH LIFTING PLATFORMS, ENTRANCE LEVEL WITH SLIDING PLATFORMS AND ONE EMPTY SPACE
- MODULAR CONSTRUCTION: DEPENDING ON THE CONDITIONS ON SITE, IT CAN BE POSSIBLE TO ADD SEGMENTS AT WILL
- LOAD PER PARKING SPACE: STANDARD 2.000 KG
OPTIONAL UP TO 2.300 KG OR 2.600 KG

APPLICATION

- FOR INTERIORS AND EXTERIORS
- ONE AND MULTI-FAMILY DWELLINGS
- HOTELS AND OFFICE BUILDINGS
- CONDOMINIUMS
- COMMERCIALS
- CAR DEALERS
- FOR PERMANENT USERS ONLY

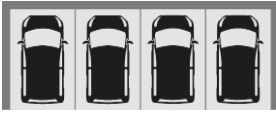

Modularer Aufbau beliebig erweiterbar

NOTE

The total height of the car including roof rail and antenna fixture must not exceed the maximum car height mentioned in the table below. Standard cars do not feature sport equipment (e.g. spoiler, etc.)

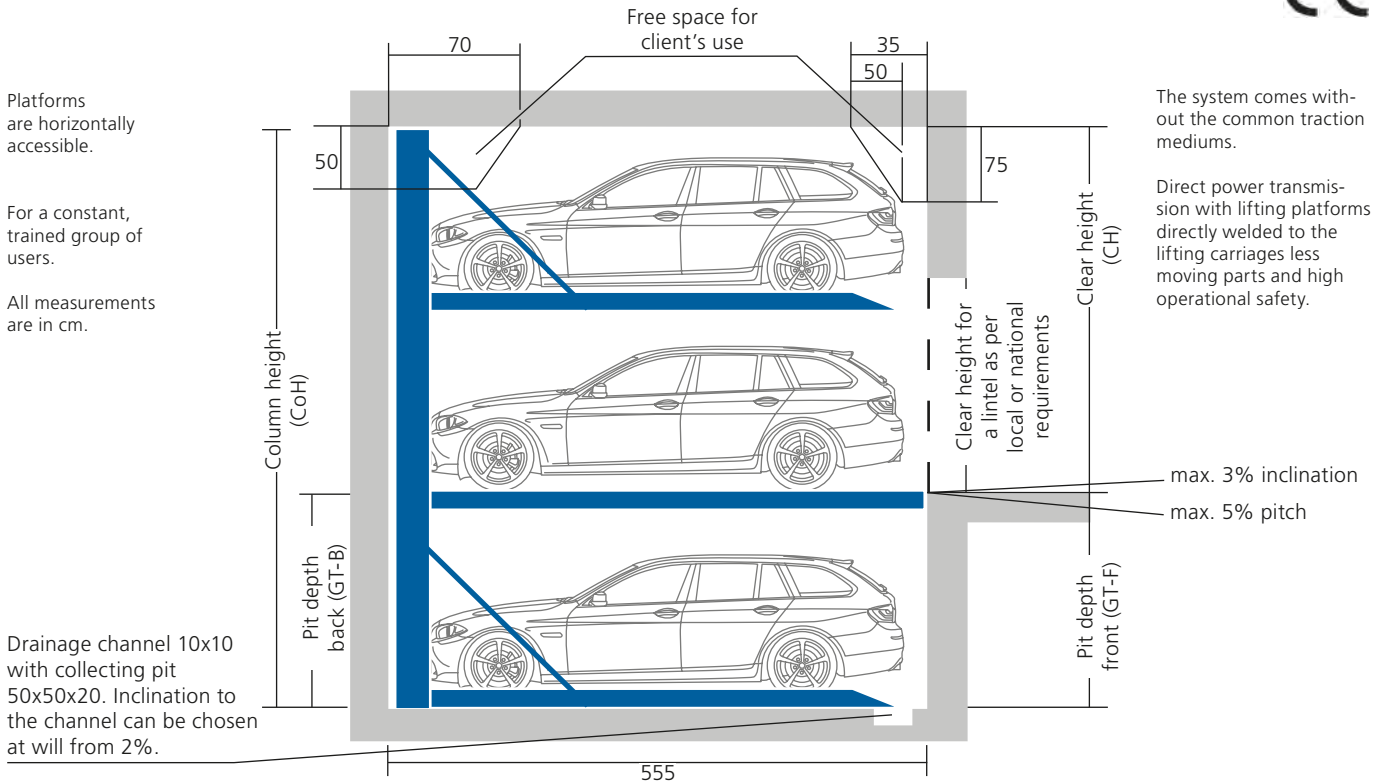

Standard system length 555 cm for vehicles with a max. length of 500 cm and a max. weight of 2.000 kg. Platforms for different vehicle length or higher vehicle weight could have impact on the system length! Further dimensions, inclusive for drive-through systems, available upon request.

Concrete: min. 18, C25, floor evenness acc. to DIN 18202 tab. 3, line 3.

PIT DEPTH FRONT (GT-F)	PIT DEPTH BACK (GT-B)	COLUMN HEIGHT (CoH) - in stages	CLEAR HEIGHT (CH) - in stages	CAR-HEIGHT BELOW	CAR-HEIGHT MIDDLE - in stages	CAR-HEIGHT ABOVE
175 or deeper	175	475 475 490 505 520	325 330 345 360 375	150	155 160 175 190 205	150*
175 or deeper	175	475 490 505 520	330 345 360 375	150	160 175 190 205	150*
185 or deeper	185	485 500 515 530	330 345 360 375	160	160 175 190 205	150*
195 or deeper	195	510 525 540	345 360 375	170	175 190 205	150*
200 or deeper	200	515 530 545	345 360 375	175	175 190 205	150*
210 or deeper	210	540 555	360 375	185	190 205	150*
220 or deeper	220	565	375	195	190 205	150*
230 or deeper	230	575	375	205	205	150*

* In case of a car-height above that is higher than 150 cm, the clear height is to be increased respectively.

VEHICLE DATA: STANDARD CAR

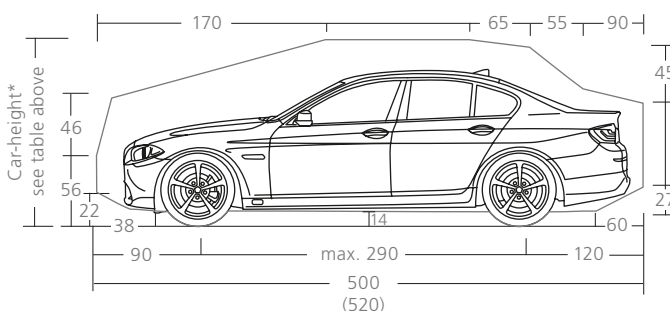

VEHICLE DATA: STANDARD ESTATE CAR

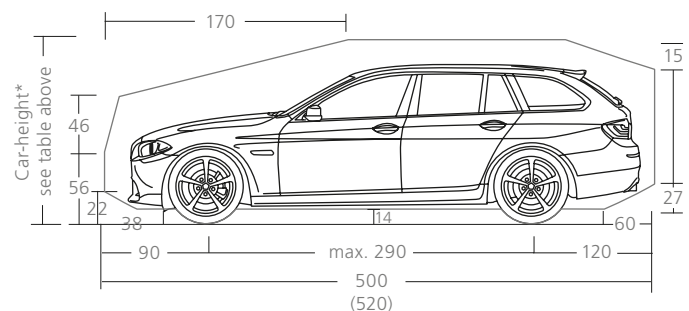

WIDTH MEASUREMENTS

EXAMPLE: 3 SEGMENTS FOR 8 PARKING SPACES

All dimensions in cm. All dimensions are minimum dimensions. Advice for planning and tendering: Generally masonry and concrete works are to be conducted according to the German norm VOB/C (DIN 18330 and DIN 18331). In the mentioned norm are pointed the tollerances that are to be fulfilled according to DIN 18202. In this norm are defined the maximum permissible dimension variations as exceedance and shortfall of the nominal size. The nominal size should be planned in order to meet the minimum dimensions necessary for the parking system.

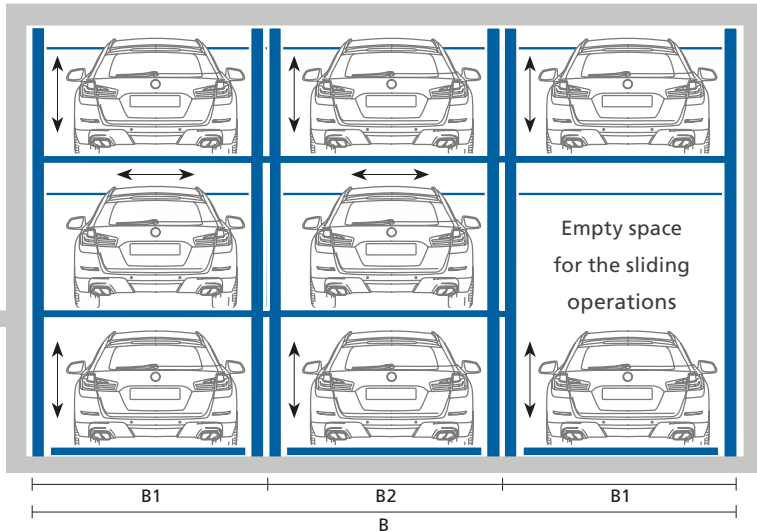

On the entrance level are sliding platforms with one empty space on the right (on the left: possible as an option). On the lower level the system is provided with lifting platforms. A lifting platform will be lifted or lowered to the empty space on the entrance level.

The smallest sinful unit is composed by 2 segments for 5 cars. The system can be extended at will by adding segments. Anyway we suggest to combine no more than 10 segments for 29 cars with a common power unit, to keep a quick access time.

System dimensions for vehicles with a max. weight of 2.000 kg. Platforms for higher vehicle weight could have impact on system dimensions! Further dimensions, inclusive for drive-through systems, available upon request.

PLATFORM WIDTH	OUTER FRAME (B1)	INNER FRAME (B2)	TOTAL MEASUREMENTS FOR x SEGMENTS									
			2	3	4	5	6	7	8	9	10	
230	260	250	520	770	1020	1270	1520	1770	2020	2270	2520	
235	265	255	530	785	1040	1295	1550	1805	2060	2315	2570	
240	270	260	540	800	1060	1320	1580	1840	2100	2360	2620	
250	280	270	560	830	1100	1370	1640	1910	2180	2450	2720	
260	290	280	580	860	1140	1420	1700	1980	2260	2540	2820	
270	300	290	600	890	1180	1470	1760	2050	2340	2630	2920	

Note: The power unit will be installed at the back wall between 2 system columns, alternatively outside the system. Power unit's measurements: (LxWxH) 45 x 22 x 60 cm. Mind the measurements of the switch cabinet (positioned outside the system) during planning! Space needed: 100 x 100 x 80 cm, including cabinet doors' opening.

THE ADVANTAGES OF OUR N5303

On the entrance, the system has no columns and therefore it offers a wide parking entrance. Another important advantage of our N5303, in comparison with the other semi-automatic systems in commerce, is that there are no wear parts, as for example chains and ropes. And what is not present, cannot break or wear out!

Summary of the positions subject to control of the N5102 in comparison with traditional systems:

NECESSARY SAFETY DEVICES	MONITORING / CONTROL			
	TRADITIONAL SYSTEMS	NUSSBAUM N5303	IN TRADITIONAL SYSTEMS	IN THE NUSSBAUM N5303
PLATFORM SUSPENSION				
Traction medium	chain/rope	not existing	necessary	not required
Chain or rope break	cause of failures	not existing	necessary	not required
Safety catch	necessary	not existing	necessary	not required
Jamming	cause of failures	not possible	necessary	not required
Chain or rope stretch	cause of failures	not existing	necessary	not required
Catch on upper/lower platform	necessary	not existing	necessary	not required

ELECTRICAL INSTALLATION AND FOUNDATION LOADS

Services covered by the NUSSBAUM Company

POS.	QUANTITY	DESCRIPTION
1	1x	Hydraulic power unit with three-phase motor 400V, 50Hz, 3,0kW
2	1x	Bus cable 1x2x0,2
	1x	Control line 1x12G1
3	1x	Control unit with Emergency-off
4	1x	Switch cabinet
5	1x	Segment box
6	1x	Segment valve
7	1x	Hydraulic valve
8	1x	Electrical motor for the sliding movement
9	1x	Supply line 5x 2,5mm ² (3 PH + N + PE) with marked leads + protective earth conductor

Installation diagram

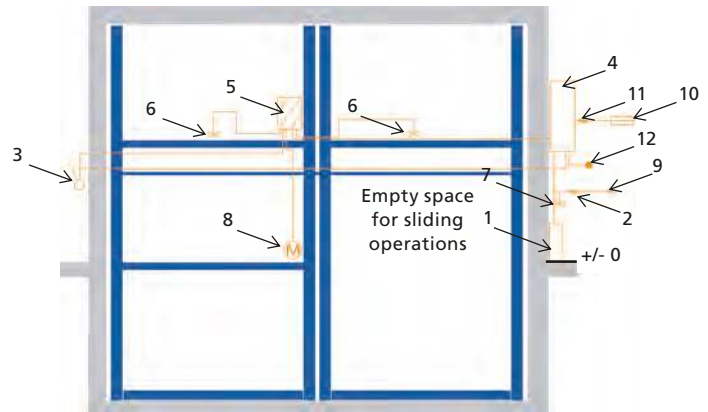

Positions 1 to 9 are covered by the Nussbaum company unless otherwise agreed in the offer or in the contract.

Services to be provided by the customer

POS.	QTY.	DESCRIPTION	POSITION	FREQUENCY
10	1x	Blade fuse or circuit breaker 3x 16A, slow acc. to DIN VDE 0100 part 430	in the supply line	1x power unit
11	1x	Supply line 5x 2,5mm ² (3 PH + N + PE) with marked leads + protective earth conductor	to the switch cabinet	1x power unit
12	1x	Equipotential bonding according to DIN EN 60204 from the connector of the foundation earth electrodes to the system		1x system

FOUNDATION LOADS AND CONSTRUCTION

Description

Foundation and pit walls must be planned so that they can absorb the loads of the parking system according to the schematic diagram shown on the right.

If necessary, in case of **heightened foundation requirements**, the chemical anchors **must be provided by the client** (deliverable by Nussbaum as option as well). The borehole for the footplates of the parking system must be 18 cm deep.

Foundation, walls and ceilings shall be realized by the customer and completed prior to assembly start and must be true to size, clean and dry. Floor and walls shall be made of armoured concrete. Concrete quality shall be at least: C25/30.

Ground view

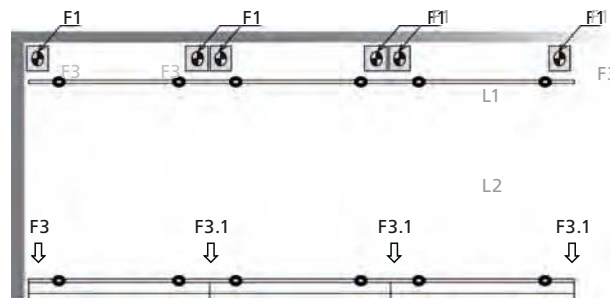

Side view

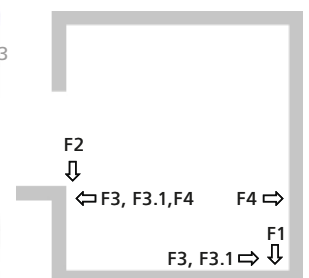

Load details

LOAD PER PARKING SPACE	VERTICAL LOADS		HORIZONTAL LOADS		
	F1	F2	F3	F3.1	F4 (WHILE DRIVING)
2.000 Kg	30 kN	30 kN	50 kN	75 kN	8 kN
2.300 kg	32 kN	32 kN	55 kN	85 kN	9 kN
2.600 Kg	35 kN	35 kN	60 kN	90 kN	10 kN

METAL SLIDING GATES

Manual metal sliding gates included in the scope of delivery - Electrical gates as option

METAL GATES FOR YOUR SYSTEM: SAFETY AND COMFORT



NOTE

The sliding gates need to be fastened to the available building structure otherwise additional expenses may occur.

Metal gates are included in the scope of delivery of your semi-automatic system. Optionally you can also choose other types of gate coverings.

For maximum comfort when driving in and out of the system you can even choose electrical gates, which can be opened and closed by remote control. This way you can comfortably sit in your car while parking your car.

PLACEMENT OF THE SLIDING GATES

There are three possibilities to install the optional sliding gates:

Layout A:

Sliding gates between the building pillars. The pillars (by client) must be positioned at least each 2 system segments).

Layout B:

Sliding gates behind the building pillars. (However, behind the gates the necessary system length of 545 cm must still be available).

Layout C:

Sliding gates in front of the building pillars.

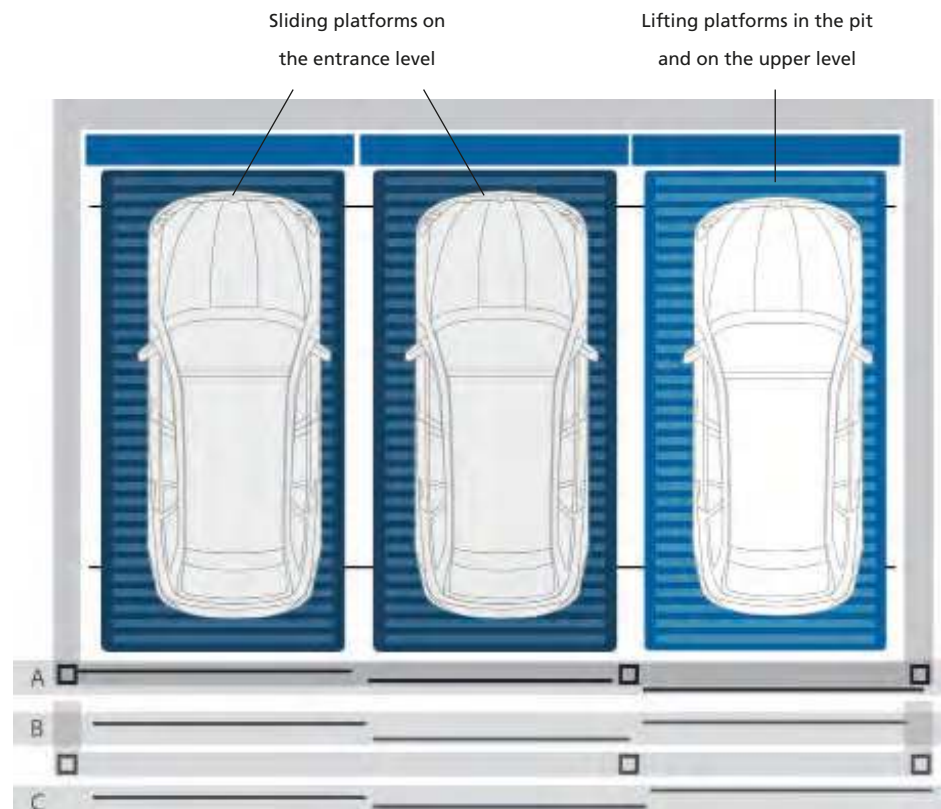

STANDARD FEATURES

Included in the scope of delivery

COMPONENT PARTS

The system comes with sliding platforms and one empty space on the entrance level and lifting platforms on the lower and upper level. Complete with hydraulic motion elements and electrical steering. Without gates, in dead man's control.

DRIVING SHEETS



Platforms with side carriers and driving sheets made of trapezoidal sheet.

MEASUREMENTS OF THE SYSTEM

Designed for:

Parking space length: 500 cm

Parking space width: 230 cm

Parking space height: from 150 cm

Load per parking space up to 2.000 kg.

CONTROL UNIT



Operation by touch screen with key switch and emergency-stop. With brief operating instructions fastened on the wall and cabling to the power unit.

HYDRAULIC POWER UNIT

Power unit „Silencio“



with hydraulic piping and cabling to the system. (The under oil unit is not noisy thanks to the motor-pumps-combination that absorbs sound and insulates form noise).

To shorten access time, we suggest to use one power unit for max. 10 segments.

Measurements in cm (LxWxH):

Power unit: 45 x 22 x 60 cm.

Switch cabinet: 100 x 100 x 76 cm (place for the cabinet doors included).

Positioning of the power unit:

Depending on the local conditions - preferably directly close to the back system columns or cylinders on the back.

CORROSION PROTECTION

C3-Line

For Regions with average snowfall and humidity levels (the standard in Germany).

C2-Line

Recommended only for regions with small or no snowfall and low humidity levels.

NOTE

We suggest periodical maintenance, care and cleaning. Take advantage of NUSSBAUM maintenance agreements.

ELECTRICAL INSTALLATION

For a list of services and interfaces please see the respective table in this brochure.

DOCUMENTATION

Brief operating instructions (fastened to the control unit), documentation (test book and operating instructions).

SAFETY DEVICES



Wedge to help position the vehicle.

Hydraulic seated valve installed at the cylinders and hydraulic power unit as non-return device, in case of a loss of pressure.

Fastening of the parking system and hydraulic power unit with stud-bolts, electrical cabling fastened with impact dowels.

Safety fences on the sides against shear and crushing points, as long as the side walls are missing and they are offered by us as extra position.

Integrated mechanical safety loop at the sliding platforms, which prevent the upper lifting platforms from lowering.

Several software-driven sensors to control the horizontal and vertical movements.

OPTIONS AND EXTRA EQUIPMENT

Available upon request - here are illustrated some examples only...

MEASUREMENTS OF THE SYSTEM

Designed for:

Parking space length: from 510 to 530cm

Parking space width: from 235 to 270cm

Parking space height: from 155 to 205 cm

Load per parking space up to 2.600 kg.

Fastening of the parking system with chemical anchors in case of heightened foundation requirements.

ALUMINIUM: PREMIUM-COVERING

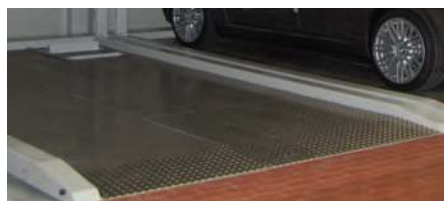

Upper platforms with Aluminium-bulb plate driving sheets. (Photo: N5102)

MORE WALKING COMFORT: CATWALKS



Catwalk on trapez. sheet for more walking comfort

Positioning on the left side. 1,5 mm zincod sheets, embossed surface. The catwalk will be screwed to the driving sheet.

CORROSION PROTECTION

C3-Line or C4-Line

Depending on the region, for higher corrosion protection.

EXTRA SOUND INSULATION



Sound insulation hood for the power unit

Airborne noise package - hood

For the power unit to reduce the airborne noise at the installation site.

Structure/borne noise package

Measures to reduce the sound propagation from the parking system to the building.

Note

- In order to comply with the norm DIN 4109/A1 Table 4 „requirements for the allowed noise level in areas in need of protection from noises coming from the technical equipment“, the perimetral parts of the garage building shall be built with a sound reduction index R_w' of at least 57 dB.

HYDRAULIC

- HVLP 32-330 oil for extreme temperature variations.
- Heated hydraulic power unit.

SLIDING GATES

Other gate coverings instead of wire mesh are available optionally.

NOTE

We suggest periodical maintenance, care and cleaning. Take advantage of NUSSBAUM maintenance agreements.

ELECTRICAL SLIDING GATES

As option you can order electrical sliding gates for maximum comfort while driving in and out of the system. The electrical gates are operated by our optional remote control.

REMOTE CONTROL



The remote control delivered as option in combination with the optional electrical gates. Available in three configurations: with 1, 2 or 3 buttons.

Each button is for a specific function, depending on the Parking space length:

1. (above): request a parking space (radio).
2. (right): close parking system gate (infrared).
3. (below): open/close external barrier or garage gate (radio).

MODEM FOR TELESERVICE

With our CAN-BUS control we can conduct remote service and maintenance via telephone. Delivery incl. modem. Within a few minutes our technicians can connect to the system and analyze the cause of the failure. most of the times it is possible to fix the problem immediately, often without the need of personnel on site.

By client: Modem DSL, DSL connection with fixed IP address and at least 1 MBit/s upstream.

SERVICES TO BE PROVIDED BY THE CUSTOMER AND PLANNING INDICATIONS

During the planning phase please observe and comply with the following notes!

SERVICES TO BE PROVIDED BY THE CUSTOMER

Safety fences

Safety fences acc. to DIN EN ISO 13857 must be provided by the customer.

Parking spaces' numeration

For the allocation of the parking spaces we suggest our customers to numerate the parking spaces.

Noise abatement measures

The compliance with these measures must be carried out by the customer acc. to norm DIN 4109: „Sound insulation in building construction“.

Electrical installation

Prior to starting the assembly the customer must provide a lockable main control switch out of the system/pit close to the power unit. Electrical services to be provided by the customer acc. to this brochure's specification.

Fire protection

The customer must agree upon the fire protection requirements and the required measures with the local fire department and realise them.

Lighting

To be carried out by the customer acc. to DIN 67528: „Lighting for parking areas and indoor car parks“.

Foundation

To be carried out by the customer acc. to the specifications in this brochure.

Control unit

The customer must make sure that a plain surface of (L x W) 50 cm x 20 cm for the installation of the control unit is directly close to the power unit and out of the platforms' moving area.

Drainage

Drainage channel 10 cm x 10 cm with collecting pit 50 cm x 50 cm x 20 cm acc. to this brochure's spec to be carried out by the customer.

Installation requirements

The compliance with installation requirements acc. to quotation.

Wall openings

In case of partition walls the customer must realise a 10 cm x 10 cm wall opening for hosting hydraulic and electrical cables.

Building permit

The customer must apply for and get the required permits in order to allow the installation of the parking system.

PLANNING INDICATIONS

Parking space width and driving lanes

While planning the parking space and driving lane dimensions please observe and comply with the local/national prescriptions for the Garages' construction. For more parking comfort we suggest you to plan parking spaces of at least 250 cm width.

Group of users

Our parking systems are conceived for a permanent and instructed group of users.

Maintenance and care

We suggest a timely conclusion of a maintenance agreement.

We suggest also to perform maintenance, care and cleaning at regular time intervals.

EG-Machinery directive

Our parking systems comply with the EG-Machinery directive and are CE certified according to the norm DIN EN 14010.

Ramps' inclination

Ramps leading to garages shall not have more than 15% inclination.

Modifications

The company Nussbaum Parking GmbH reserves the right to make dimensional, design and technical modifications.