

## Storeparker N2102

**MORE SAFETY**  
DUE TO HYPERFLOW-  
TECHNOLOGY

**FLEXIBILITY**  
DUE TO MODULAR  
PRODUCT-VARIANTS

**IDEAL  
LAND USE**



## Intermediate storage for up to 2.600 kg



### Parking of vehicles on 2 levels

The hydraulic STOREPARKER N2102 is used to double the number of parking space without a pit. The parking system serves as dependent parking, which means (the space below has to be free) to park on the platform above in and out.

#### The STOREPARKER N2102 at a glance

- 100% more parking space
- dependent parking on 2 levels, above-ground without pit
- the platform is accessible horizontally
- intermediate storage and parking of vehicles for up to 2.600 kg
- ideal synchronism due to the new and patented hydraulic-technology of Nussbaum
- trapezoidal sheets as platform surface
- flexible due to different system heights
- low requirements on the installation area
- available for indoor and outdoor operation
- modular installation in segmental construction
- operation via key-switch (lifting/lowering) in dead man's control

#### Particularly suitable for

- ✓ car dealerships
- ✓ car repair workshops
- ✓ car rental areas
- ✓ private car parks
- ✓ valet parking

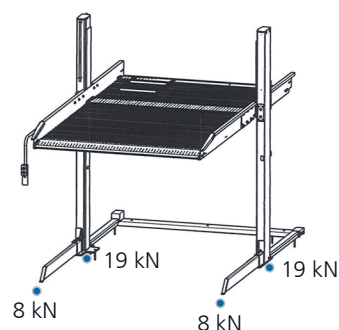

TECHNICAL DATA	
Vehicle capacity (kg)	2.000 / 2.300 / 2.600
Column height (cm)	300 / 315
Platform length (cm)	379 / 436 / 480 / 500
Platform width* (cm)	230 / 240 / 250
System width (cm)	260 / 270 / 280
Motor Power (kW)	3
Electricity supply (Volt / Hz)	400 / 50

Power unit	width	length	height
31 l	205 mm	571 mm	577 mm
54 l	205 mm	1071 mm	582 mm
80 l	205 mm	1071 mm	750 mm

clear height	column height	car height below	car height above
318 cm	300 cm	150 cm	150 cm **
328 cm	300 cm	160 cm	150 cm **
338 cm	300 cm	170 cm	150 cm **
348 cm	300 cm	180 cm	150 cm **
358 cm	315 cm	190 cm	150 cm **
368 cm	315 cm	200 cm	150 cm **

\* Other platform widths are available on request.

\*\* The car height above depends on the available ceiling height.

The total system height depends on the car-height above. Please feel free to contact us, and we are looking forward to assist you in the planing phase.